

**Oil Content Analyzer
OCMA-500**

Instruction Manual

CODE:GZ0000331784F

Preface

This manual describes the operation of the Oil Content Analyzer, OCMA-500.

Be sure to read this manual before using the product to ensure proper and safe operation of the product. Also safely store the manual so it is readily available whenever necessary.

Product specifications and appearance, as well as the contents of this manual are subject to change without notice.

Warranty and responsibility

HORIBA Advanced Techno Co., Ltd. warrants that the Product shall be free from defects in material and workmanship and agrees to repair or replace free of charge, at option of HORIBA Advanced Techno Co., Ltd., any malfunctioned or damaged Product attributable to responsibility of HORIBA Advanced Techno Co., Ltd. for a period of one (1) year from the delivery unless otherwise agreed with a written agreement. In any one of the following cases, none of the warranties set forth herein shall be extended;

- Any malfunction or damage attributable to improper operation
- Any malfunction attributable to repair or modification by any person not authorized by HORIBA Advanced Techno Co., Ltd.
- Any malfunction or damage attributable to the use in an environment not specified in this manual
- Any malfunction or damage attributable to violation of the instructions in this manual or operations in the manner not specified in this manual
- Any malfunction or damage attributable to any cause or causes beyond the reasonable control of HORIBA Advanced Techno Co., Ltd. such as natural disasters
- Any deterioration in appearance attributable to corrosion, rust, and so on
- Replacement of consumables

HORIBA Advanced Techno Co., Ltd. SHALL NOT BE LIABLE FOR ANY DAMAGES RESULTING FROM ANY MALFUNCTIONS OF THE PRODUCT, ANY ERASURE OF DATA, OR ANY OTHER USES OF THE PRODUCT.

Trademarks

Company names and brand names are either registered trademarks or trademarks of the respective companies. (R), (TM) symbols may be omitted in this manual.

Regulations

Conformable Directive

This equipment conforms to the following directives and standards:



EMC: EN61326-1
Class B, Basic electromagnetic environment
Safety: EN61010-1
RoHS: EN50581
9. Industrial monitoring and control instruments

Warning: This product is not intended for use in industrial environments. In an industrial environment, electromagnetic environmental effects may cause the incorrect performance of the product in which case the user may be required to take adequate measures.

■ Installation environment

This product is designed for the following environment.

- Overvoltage Category II
- Pollution degree 2

■ Information on disposal of electrical and electronic equipment and disposal of batteries and accumulators

The crossed out wheeled bin symbol with underbar shown on the product or accompanying documents indicates the product requires appropriate treatment, collection and recycle for waste electrical and electronic equipment (WEEE) under the Directive 2012/19/EU, and/or waste batteries and accumulators under the Directive 2006/66/EC in the European Union.

The symbol might be put with one of the chemical symbols below. In this case, it satisfies the requirements of the Directive 2006/66/EC for the object chemical.

This product should not be disposed of as unsorted household waste.

Your correct disposal of WEEE, waste batteries and accumulators will contribute to reducing wasteful consumption of natural resources, and protecting human health and the environment from potential negative effects caused by hazardous substance in products.

Contact your supplier for information on applicable disposal methods.



Cd



Pb

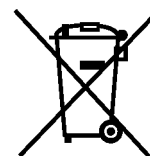

Hg

FCC rules

Any changes or modifications not expressly approved by the party responsible for compliance shall void the user's authority to operate the equipment.

■ Warning

This equipment has been tested and found to comply with the limits for a Class A digital device, pursuant to part 15 of the FCC Rules. These limits are designed to provide reasonable protection against harmful interference when the equipment is operated in a commercial environment. This equipment generates, uses, and can radiate radio frequency energy and, if not installed and used in accordance with the instruction manual, may cause harmful interference to radio communications.

Operation of this equipment in a residential area is likely to cause harmful interference in which case the user will be required to correct the interference at his own expense.

Korea certification

■ B급 기기 (가정용 방송통신기자재)

이 기기는 가정용(B 급) 전자파적합기기로서 주로 가정에서 사용하는 것을 목적으로 하며, 모든 지역에서 사용할 수 있습니다.

For Your Safety

Hazard classification and warning symbols

Warning messages are described in the following manner. Read the messages and follow the instructions carefully.

● Hazard classification



This indicates an imminently hazardous situation which, if not avoided, will result in death or serious injury. This is to be limited to the most extreme situations.



This indicates a potentially hazardous situation which, if not avoided, could result in death or serious injury.



This indicates a potentially hazardous situation which, if not avoided, may result in minor or moderate injury. It may also be used to alert against unsafe practices.

● Warning symbols









Description of what should be done, or what should be followed







Description of what should never be done, or what is prohibited

Safety precautions

This section provides precautions for using the product safely and correctly and to prevent injury and damage. The terms of DANGER, WARNING, and CAUTION indicate the degree of imminency and hazardous situation. Read the precautions carefully as it contains important safety messages.

 WARNING	
	Electric shock To prevent electric shock, ground the product. Do not ground the product to dangerous places such as a gas pipe.
	Samples may be dangerous substances. Fully understand the properties of the samples to be measured, and handle them appropriately.
	Fire <ul style="list-style-type: none">• For your safety, make sure to unplug the power plug from the electrical outlet when not in use.• Clear dust on the power plug periodically (a few times a year). If the power supply cord is left plugging into the electrical outlet for a long period of time, electrical tracking may occur due to dust and moisture, and it may result in an ignition or a fire.
	Fire or electric shock <ul style="list-style-type: none">• Do not bundle the power supply cord during use.• Do not damage, bend, or stretch the power supply cord forcibly.• If it cannot be plugged into an electrical outlet firmly, stop use of the power supply cord. If may result in overheating, fire, or an electrical shock.
	Be sure not to disassemble or modify the product, except as instructed in this manual. It may cause electric shock or product failure.

 CAUTION	
	Chemical hazard (solvent S-316) Inhalation or accidental ingestion of a large amount of solvent S-316 may be harmful. Observe the following rules when handling: <ul style="list-style-type: none">• Ventilate the work area sufficiently.• Wear a protective mask and protective gloves.• Wash hands well after handling the solvent.
	Chemical hazard (hydrochloric acid) Hydrochloric acid is toxic by skin or eye exposure. If it touches the skin, immediately rinse with water. If it reaches the eyes, rinse immediately under a large amount of running water and get medical attention.
	During dispensing liquids into the extraction tank, limit the solvent amount to 10 mL or less and the amount of the measurement liquid to 20 mL or less, so that the total volume of liquid does not exceed the upper limit line (30 mL). If the liquid exceeds the upper limit line, the liquid may leak and cause short-circuit in the internal wiring of the product. If liquid containing hydrochloric acid leaks and comes in contact with the skin, irritation and burning may occur.
	Discard the liquid collected in the beakers before overflow. If liquid containing hydrochloric acid overflows and comes in contact with the skin, irritation and burning may occur.



CAUTION



Take care not to pinch your fingers when opening or closing the right cover.
During closing the right cover, do not release your hand until you hear a click sound.



Avoid any impact on the product.
If the product is damaged and liquid leaks, the internal wiring may short-circuit.
If liquid containing hydrochloric acid leaks and comes in contact with the skin, irritation and burning may occur.

Product Handling Information

Operational precautions

Use of the product in a manner not specified by the manufacturer may impair the protection provided by the product. And it may also reduce product performance.

Observe the cautions below.

- This product is specified for use with H-997. Do not use any other solvent than H-997 to perform extraction and measurement. It may cause product failure.
- Samples containing emulsifying substances (surface-active substances) cannot be measured.
- Samples containing acetone or toluene cannot be measured. These samples may damage the product.
- Samples containing impurities and samples with high viscosity should be filtered, diluted, or otherwise preprocessed appropriately before measurement. If measured without preprocessing, the tubing and valves may become clogged and product may get damaged.
- Take care not to spill samples or solvents on the main unit. It may cause product failure.
- Avoid operating and storing the product under the following locations and conditions:
 - Humidity above 80%.
 - Temperature less than 0°C or over 40°C
 - Locations subject to sudden temperature changes
 - Direct exposure to sunlight
 - Presence of corrosive gases
 - Dusty locations
 - Poor ventilation
 - Locations subject to vibration
 - Close proximity to large electric motors or voltage transformers
- When handling liquids during measurement, calibration, or otherwise, remove the USB memory stick from the USB memory port and cap the port. If a liquid spills on a USB memory stick or the USB memory port, the liquid may enter the interior of the product from the USB memory port and cause product damage.
- Do not overturn the main unit. It may cause liquid to leak from the unit inside.
- Do not press the keys or the screen with a sharp or hard object.
- Do not block the fan vent on the back of the main unit.
- Before performing maintenance or inspection, read and understand the chapter "Maintenance" (page 106) in this manual.
- Wipe with water when cleaning the exterior of the product, never use the organic solvent.
- Make sure that the power supply voltage is correct for the product before switching the power ON.
- When the product will not be used for an extended period of time, remove the plug from the power outlet.
- Do not use the provided power cable for other than this product.

Solvent handling precautions

It is recommended that new solvent from the same production lot is used for calibration liquid preparation, zero calibration, span calibration, and measurement. Solvents from different production lots may have different mix ratios.

If it is necessary to use solvents from different production lot or reprocessed solvent, mix all the volumes to be used in a glass container, in order to equalize all mix ratios.

Disposal of the product

When disposing of the product, follow the related laws and/or regulations of your country.

Manual Information

Description in this manual

Note

This interprets the necessary points for correct operation and notifies the important points for handling the product.

Reference

This indicates the part where to refer for information.

Tip

This indicates reference information.

Original language

This is the original in English.

Contents

Product Outline	1
Overview	1
Accessories	2
Part names	3
Exterior	3
Extraction tank window	4
Right inside	4
Operation buttons	5
LCD	6
Main Unit Setup	9
Putting the valve stickers	9
Placing the absorbent sheet	9
Basic Operation	10
Power ON	10
Power OFF	11
Drainage mode operation	12
Operations while the sequence is in progress	12
Pause	12
When an error occurs	12
Connecting a USB memory stick	13
Screen operations in the manual measurement/calibration mode	14
Using pop-up screens	16
Selection list display	16
Numeric keys	17
Character keys	18
Preparation	19
Measurement preparation cautions	19
Glassware	20
Items required	20
Placing the beakers for drainage	20
Cleaning the measuring cylinders or syringes	20
Zero liquid for calibration	21
Span liquid for calibration	21

Using B-heavy oil	21
Hydrochloric acid	22
Hydrochloric acid preparation method	22
Condition settings	23
Calibration condition settings	23
Measurement condition settings	23
Calibration	24
Calibration cautions	24
Points to check prior to calibration	26
Points to check prior to zero calibration	26
Points to check prior to span calibration	26
Items required	26
Zero calibration	26
Span calibration	26
Automatic zero calibration	27
Automatic span calibration	28
Manual zero calibration	30
Manual span calibration	32
Calibration (ASTM D7066-4)	34
Calibration cautions	34
Points to check prior to calibration	36
Points to check prior to zero calibration	36
Points to check prior to span calibration	36
Items required	36
Zero calibration	36
Span calibration	36
Zero liquid for calibration	37
Span liquid for calibration	37
Hydrochloric acid	38
Hydrochloric acid preparation method	38
Automatic zero calibration	39
Automatic span calibration	40
Manual zero calibration	43
Manual span calibration	44

Measurement	47
Measurement cautions	47
Preprocessing	49
Removing fine particles	49
Performing preliminary extraction outside the product	49
Points to check prior to measurement	49
Items required	50
Automatic measurement	50
Deciding the extraction time	50
Flow scheme of operation	51
Procedure	52
Semi-automatic measurement	54
Flow scheme of operation	54
Procedure	55
Manual measurement	58
Flow scheme of operation	58
Procedure	59
Examples of measurement by extraction outside the product	61
Oil content in water	61
Oil content in or on solids	67
 Data Management	 70
Data Top screen	70
Current Alarm screen	71
Measurement History screen	72
Calibration History screen	73
USB Memory screen	74
Execution confirmation for [Save Measurement History]	76
Execution confirmation for [Save Calibration History]	77
Execution confirmation for [Save Settings]	79
Memory Clear screen	82
Execution confirmation for [Clear Measurement History]	83
Execution confirmation for [Clear Calibration History]	84
Execution confirmation for [Initialize Setting]	84
Execution confirmation for [Initialize Calibration Value]	85
 Setting	 86
Setting Top screen	86

Measurement Setting screen	87
Extraction Time	89
Separation Time	89
Fill Cell Time	90
Meas. Limit	90
Drainage Time	91
Number of Purge.	91
Meas. Mode	92
Measurement Unit.	92
Solvent Vol.	93
Sample Vol.	94
Conc. Correction	95
Zero Shift Value	96
Use Light.	96
Confirm Save	97
Save Memo	97
Display Negative	98
Display Raw Data	98
Calibration Setting screen.	99
Span Point	100
Extraction Time	100
Separation Time	101
Number of Purge.	101
Calib. Mode	102
Calib. Point	102
Calib. Curve	102
System Setting screen	103
Language	104
B-Light Off Time	104
Date	105
Time	105
Maintenance	106
Contact for maintenance.	106
Maintenance item list	106
Rinsing the flow paths.	107
Maintenance interval guideline	107
Items required	107
Rinsing procedure.	107
Inspecting the absorbent sheet.	108
Maintenance interval guideline	108
Items required	108
Work procedure	108
Cleaning the fan filter	109
Maintenance interval guideline	109
Items required	109

Work procedure	109
Washing the fan filter	110
Maintenance interval guideline	110
Items required	110
Work procedure	110
Washing the extraction tank	111
Maintenance interval guideline	111
Items required	111
Work procedure	111
Removing liquid from the air hole of the extractor	116
Maintenance interval guideline	116
Items required	116
Work procedure	116
Replacing the water filter	118
Maintenance interval guideline	118
Items required	118
Replacement procedure	118
Drying the measurement cell	121
Maintenance interval guideline	121
Items required	121
Drying procedure	121
Troubleshooting	125
Alarm displays and actions	125
List of alarms	125
Problems not indicated by an alarm	127
Problems related to product operation	127
Problems related to measured values	127
Reference	130
About this product	130
Measurement principle	130
Measurement time	131
Conversion of measurement units	131
mg/kg	131
mg/g	131
mg/PC	131
Solvent S-316	132
Characteristics	132
Properties of S-316	132
Reclamation of solvent	132
Storing solvent	133

Disposing of solvent	133
Frequently asked questions	134
Solvents	134
Measurement	134
Solvent reclamation unit SR-305	136
Product Information	138
Specifications	138
List of optional parts	138

Figures

Fig. 1	Exterior	3
Fig. 2	Extraction tank window	4
Fig. 3	Right inside	4
Fig. 4	Operation buttons.....	5
Fig. 5	Measurement/calibration screen example	6
Fig. 6	Example of item selection screen	7
Fig. 7	Pop-up screen example (selection list)	7
Fig. 8	Pop-up screen example (numeric keys).....	8
Fig. 9	Input screen example (character keys).....	8
Fig. 10	Positions of the valve stickers	9
Fig. 11	Tray in the main unit.....	9
Fig. 12	Power cable connection	10
Fig. 13	Initial screen	10
Fig. 14	Measurement Top screen	11
Fig. 15	Drainage mode - Drainage	12
Fig. 16	Inserting a USB memory stick.....	13
Fig. 17	USB icon	13
Fig. 18	Example of instantaneous value measurement screen (manual measurement)	14
Fig. 19	Example of selection list pop-up screen.....	16
Fig. 20	Example of numeric key pop-up screen.....	17
Fig. 21	Example of character key pop-up screen.....	18
Fig. 22	Placing beakers for drainage	20
Fig. 23	Start of the automatic zero calibration mode.....	27
Fig. 24	Display of automatic zero calibration result.....	28
Fig. 25	Start of the automatic span calibration mode.....	28
Fig. 26	Display of automatic span calibration result.....	29
Fig. 27	Start of the manual zero calibration mode	30
Fig. 28	Manual zero calibration - Instantaneous value measurement.....	30
Fig. 29	Manual zero calibration - Measurement.....	31
Fig. 30	Manual zero calibration - Result.....	31
Fig. 31	Start of the manual span calibration mode.....	32
Fig. 32	Manual span calibration - Instantaneous value measurement.....	32
Fig. 33	Manual span calibration - Measurement	33
Fig. 34	Manual span calibration - Result.....	33
Fig. 35	Start of the automatic zero calibration mode.....	39
Fig. 36	Display of automatic zero calibration result.....	40
Fig. 37	Start of the automatic span calibration (1st to 5th point) mode.....	40
Fig. 38	Display of automatic span point 1 result	41
Fig. 39	Start of the manual zero calibration mode	43
Fig. 40	Manual zero calibration - Instantaneous value measurement.....	43
Fig. 41	Manual zero calibration - Measurement.....	44
Fig. 42	Manual zero calibration - Result.....	44
Fig. 43	Start of the manual span calibration (1st to 5th point) mode.....	45
Fig. 44	Manual 1st span calibration - Instantaneous value measurement	45
Fig. 45	Manual 1st span calibration- Measurement	46
Fig. 46	Manual 1st span calibration - Result	46
Fig. 47	Removal of fine particles	49
Fig. 48	Operation flow of automatic measurement	51
Fig. 49	Start of the automatic measurement mode	52
Fig. 50	Auto Measurement - Measurement.....	53
Fig. 51	Operation flow of semi-automatic measurement.....	54
Fig. 52	Start of the semi-automatic measurement mode	55

Fig. 53	Semi-automatic measurement - Extraction.....	55
Fig. 54	Semi-automatic measurement - Layer separation.....	56
Fig. 55	Semi-automatic measurement - Fill Cell.....	56
Fig. 56	Semi-automatic measurement - Measurement.....	56
Fig. 57	Operation flow of manual measurement.....	58
Fig. 58	Start of the manual measurement mode.....	59
Fig. 59	Manual measurement - Instantaneous value measurement.....	59
Fig. 60	Manual measurement - Measurement.....	60
Fig. 61	Manual measurement - Result.....	60
Fig. 62	Mixing solvent and sample water by shaking.....	62
Fig. 63	Checking layer separation.....	62
Fig. 64	Extraction.....	64
Fig. 65	Separating the solvent layer.....	65
Fig. 66	Visually checking the solvent layer.....	65
Fig. 67	Removing water from the solvent layer.....	65
Fig. 68	Oil content extraction from part (immersion).....	68
Fig. 69	Data Top screen.....	70
Fig. 70	Current Alarm screen.....	71
Fig. 71	Measurement History screen.....	72
Fig. 72	Calibration History screen.....	73
Fig. 73	USB Memory screen.....	74
Fig. 74	Execution confirmation for [Save Measurement History].....	76
Fig. 75	Execution confirmation for [Save Calibration History].....	77
Fig. 76	Execution confirmation for [Save Settings].....	79
Fig. 77	Setting file example.....	81
Fig. 78	Memory Clear screen.....	82
Fig. 79	Execution confirmation for [Clear Measurement History].....	83
Fig. 80	Execution confirmation for [Clear Calibration History].....	84
Fig. 81	Execution confirmation for [Initialize Setting].....	84
Fig. 82	Execution confirmation for [Initialize Calibration Value].....	85
Fig. 83	Setting Top screen.....	86
Fig. 84	Measurement Setting screen.....	87
Fig. 85	Extraction Time screen.....	89
Fig. 86	Separation Time screen.....	89
Fig. 87	Fill Cell Time screen.....	90
Fig. 88	Meas. Limit screen.....	90
Fig. 89	Drainage Time screen.....	91
Fig. 90	Number of Purge screen.....	91
Fig. 91	Meas. Mode screen.....	92
Fig. 92	Measurement Unit screen.....	92
Fig. 93	Solvent Vol. screen.....	93
Fig. 94	Sample Vol. screen.....	94
Fig. 95	Conc. Correction screen.....	95
Fig. 96	Zero Shift Value screen.....	96
Fig. 97	Use Light screen.....	96
Fig. 98	Confirm Save screen.....	97
Fig. 99	Save Memo screen.....	97
Fig. 100	Display Negative screen.....	98
Fig. 101	Display Raw Data screen.....	98
Fig. 102	Calibration Setting screen.....	99
Fig. 103	Span Point screen.....	100
Fig. 104	Extraction Time screen.....	100
Fig. 105	Separation Time screen.....	101

Fig. 106	Number of Purge screen	101
Fig. 107	Calib. Mode screen	102
Fig. 108	Calib. Point screen	102
Fig. 109	System Setting screen	103
Fig. 110	Language screen	104
Fig. 111	B-Light Off Time screen	104
Fig. 112	Date screen	105
Fig. 113	Time screen	105
Fig. 114	Tray	108
Fig. 115	Removing the fan filter	109
Fig. 116	Cleaning the fan filter	109
Fig. 117	Removing the fan filter	110
Fig. 118	Removing the sample inlet	112
Fig. 119	Latch knobs	112
Fig. 120	Extractor	112
Fig. 121	Correct packing position	113
Fig. 122	Incorrect packing position	113
Fig. 123	Extraction tank on the packing	113
Fig. 124	Extraction tank on the packing	114
Fig. 125	Packing runs off the inside of the extraction tank	114
Fig. 126	Removing the sample inlet	116
Fig. 127	Latch knobs	116
Fig. 128	Removing liquid from the air hole	117
Fig. 129	Opening the right cover	119
Fig. 130	Removing the joints	119
Fig. 131	Replacing the water filter element	120
Fig. 132	Opening the right cover	122
Fig. 133	Removing the joints	122
Fig. 134	Replacing the water filter element	123
Fig. 135	Lower hole on the filter block	123
Fig. 136	Infrared absorption spectrums of solvent S-316 and oil	130

Tables

Table 1	Operable buttons with the instantaneous value measurement screen	14
Table 2	Operable buttons with a selection list pop-up screen	16
Table 3	Operable buttons with a numeric key pop-up screen	17
Table 4	Operable buttons with a character key pop-up screen	18
Table 5	Example of span liquid preparation	21
Table 6	Menu on the Data Top screen	70
Table 7	Button functions with the Data Top screen	70
Table 8	Button functions with the Current Alarm screen	71
Table 9	Button functions with the Measurement History screen.....	72
Table 10	Button functions with the Calibration History screen	73
Table 11	Menu on the USB Memory screen.....	74
Table 12	Button functions with the USB Memory screen	75
Table 13	Button functions with execution confirmation for [Save Measurement History]	76
Table 14	Button functions with execution confirmation for [Save Calibration History]	77
Table 15	Button functions with execution confirmation for [Save Settings]	79
Table 16	Menu on the Memory Clear screen	82
Table 17	Button functions with the Memory Clear screen	82
Table 18	Button functions with execution confirmation for [Clear Measurement History].....	83
Table 19	Button functions with execution confirmation for [Clear Calibration History].....	84
Table 20	Button functions with execution confirmation for [Initialize Setting]	84
Table 21	Button functions with execution confirmation for [Initialize Calibration Value] 85	85
Table 22	Menu on the Setting Top screen.....	86
Table 23	Button functions with the Setting Top screen	86
Table 24	Items on the Measurement Setting screen	87
Table 25	Button functions with the Measurement Setting screen.....	88
Table 26	Items on the Calibration Setting screen.....	99
Table 27	Button functions with the Calibration Setting screen	99
Table 28	Items on the System Setting screen	103
Table 29	Button functions with the System Setting screen.....	103
Table 30	Maintenance items.....	106







Product Outline

Overview

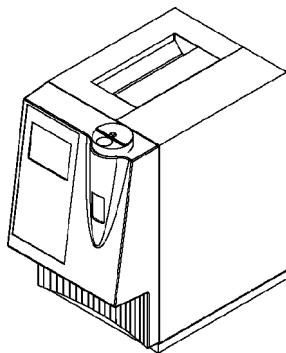
OCMA-500 is a compact automated oil content analyzer using the solvent S-316. The solvent extracts the oil content from a sample, binds it and is being measured by the infrared detector. Simple button operations execute extraction, measurement, and drainage automatically. OCMA-500 conforms to ASTM D7066-4.

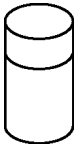
Accessories

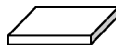
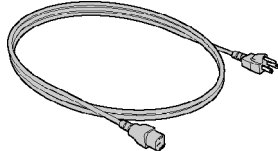
The package contains the main unit and accessories indicated below. Make sure that none of the items are missing or damaged.

Name	Remarks	Quantity	Image
Main unit	OCMA-500	1	
Dropper	Polyethylene, 2.5 mL	1	
B-heavy oil	10 mL	1	
Filter element	For water filter	5	
Absorbent sheet	For the internal tray (refer to page 9)	1	
Power cable	-	1	
Valve stickers	For operation buttons (refer to page 9)	2	
Manual	This manual	1	

Part names

Exterior

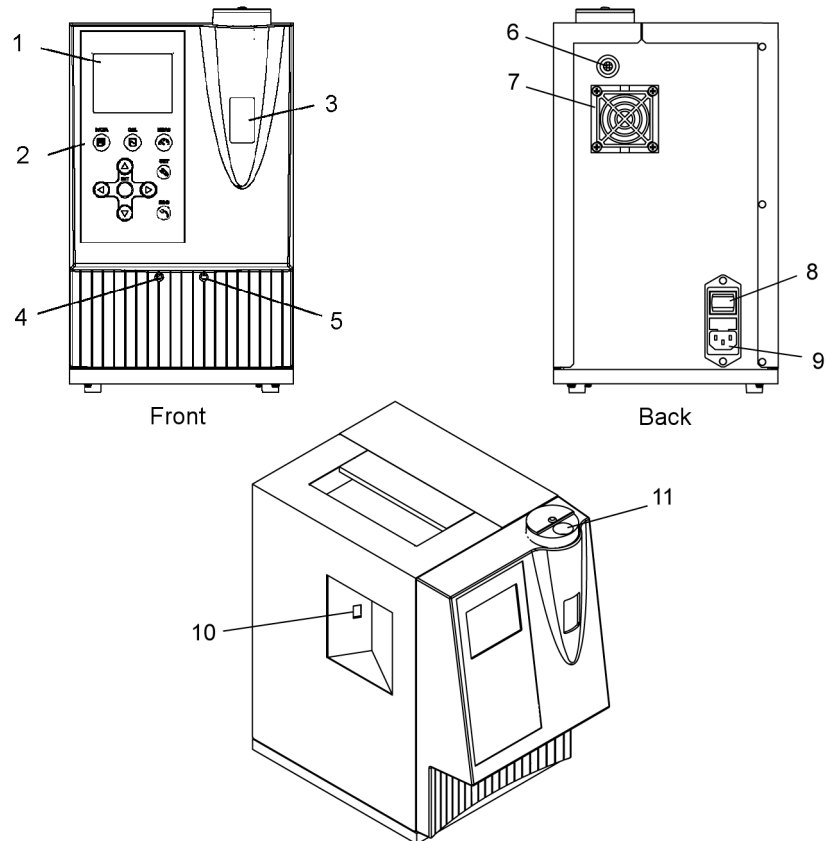

Fig. 1 Exterior

No.	Name	Description
1	LCD	This displays measurement results and items necessary for various operations.
2	Operation buttons	Buttons for performing a variety of operations
3	Extraction tank window	Allows you to check conditions inside the extraction tank.
4	Drainage outlet from measurement cell	Liquid is drained from the measurement cell through this outlet.
5	Drainage outlet from extraction tank	Liquid is drained from the extraction tank through this outlet.
6	Air vent pipe	This vent allows keeping the flow path at the atmospheric pressure.
7	Fan vent	A fan for internal temperature adjustment is located inside this vent.
8	Power switch	Switches the power of this product ON and OFF.
9	Power cable connector	Connects the provided power cable.
10	USB memory port	A USB memory stick can be inserted into this port.
11	Sample inlet	Dispense the measurement liquid into this inlet.

Note

Some USB memory stick may not work with the OCMA.
 Use a FAT/FAT32 formatted USB memory stick. Other formats may not be available with this product.
 Even FAT/FAT32 formatted, some USB memory sticks may not work. In this case, try other type.
 If you need the USB memory stick manufactured and verified by HORIBA Advanced Techno, contact your local dealer.

■ **Extraction tank window**

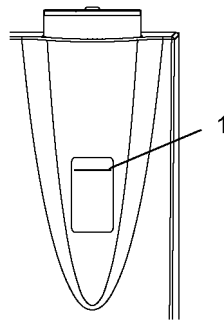

Fig. 2 Extraction tank window

No.	Name	Description
1	Upper limit line	30 mL line. Indicates the maximum amount of liquid that can be dispensed.

■ **Right inside**

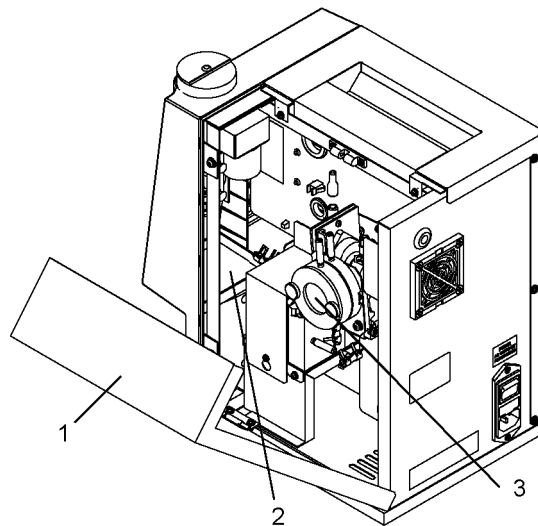

Fig. 3 Right inside

No.	Name	Description
1	Right cover	Open to perform water filter maintenance.
2	Tray	Put the absorbent sheet on this tray to catch overflows from the extraction tank.
3	Water filter	Separates water from the solvent.

Note

Always keep the right cover closed during measurement. Stable measurement cannot be performed when the right cover is open.

■ Operation buttons

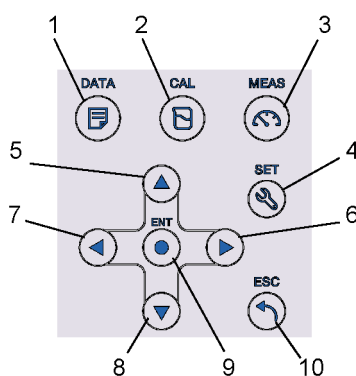



Fig. 4 Operation buttons

No.	Name	Image	Description
1	DATA button		Press this button to open the Data Top screen (refer to "Data Top screen" (page 70)).
2	CAL button		Press this button with the Measurement Top screen appearing to move to the automatic zero calibration mode or manual zero calibration mode, depending on the calibration mode setting (refer to the chapter "Calibration" (page 24)).
3	MEAS button		Press this button to move to the currently set measurement mode (refer to the chapter "Measurement" (page 47)).
4	SET button		Press this button to move to the Setting Top screen (refer to "Setting Top screen" (page 86)).
5	Up button		Press this button to change selections. The item above the currently selected item will be selected. In the manual mode, press this button to open and close the fill cell valve (refer to "Screen operations in the manual measurement/calibration mode" (page 14)).
6	Right button		Press this button to change selections. The item to the right of the currently selected item will be selected. If there is the next page, the next page will be displayed. In the manual mode, press this button to switch the stirring motor ON and OFF (refer to "Screen operations in the manual measurement/calibration mode" (page 14)).
7	Left button		Press this button to change selections. The item to the left of the currently selected item will be selected. If there is the previous page, the previous page will be displayed.
8	Down button		Press this button to change selections. The item below the currently selected item will be selected. In the manual mode, press this button to open and close the drainage valve (refer to "Screen operations in the manual measurement/calibration mode" (page 14)).

No.	Name	Image	Description
9	ENT button		Press this to enter the current selection or value, or move to the next action. In the manual mode, press this button to start measurement (refer to "Screen operations in the manual measurement/calibration mode" (page 14)).
10	ESC button		Press to undo the last action and return to the previous process. When pressed during measurement, measurement stops or is paused. In the manual mode, press this button to return the mode start state (refer to "Screen operations in the manual measurement/calibration mode" (page 14)).

■ LCD

Tip

The LCD backlight will be turned OFF automatically when the period of the set [B-Light Off Time] has passed after the last button operation (refer to "B-Light Off Time" (page 104)). Any button operations turn ON the light again.

● Measurement/calibration screen example

This screen appears when measurement or calibration is performed.

Reference

- "Calibration" (page 24)
- "Measurement" (page 47)

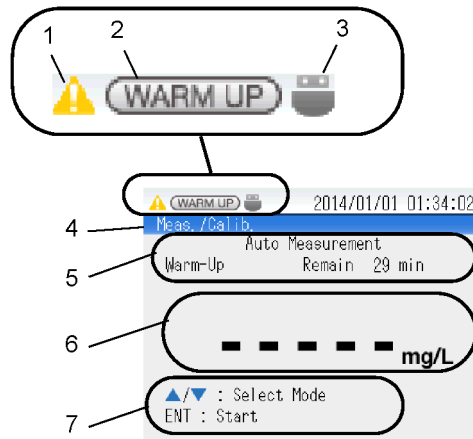

Fig. 5 Measurement/calibration screen example

No.	Name	Description
1	Alarm icon	Blinks when an abnormal condition occurs during measurement (refer to "Alarm displays and actions" (page 125)). Yellow: Caution alert Red: Warning alarm
2	Warm-up icon	Blinks for 30 minutes after the power is turned ON.
3	USB icon	Lights up while a USB memory stick is inserted.
4	Screen title	Indicates the name of the screen.
5	Process display	Shows the measurement or calibration process.
6	Measured value display	Shows the measured value.
7	Operation guide display	Shows the button operations that are used to move to the next action.

● Example of item selection screen

This screen appears for the operations of data management or setting.

Reference

- "Data Top screen" (page 70)
 - "Setting Top screen" (page 86)
-



Fig. 6 Example of item selection screen

● Example of pop-up screen

The pop-up screen below appears when needed for selection/entry in setting operations.

● Selection list display

This appears when a setting item of selection type is selected.

Reference

- "Selection list display" (page 16)
 - "Setting" (page 86)
-

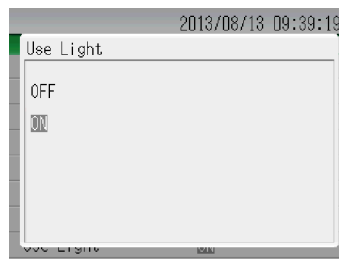

Fig. 7 Pop-up screen example (selection list)

● **Numeric keys**

These appear when the settings function is used to select a setting item that requires entry of a numerical value.

Reference

- "Numeric keys" (page 17)
 - "Setting" (page 86)
-



Fig. 8 Pop-up screen example (numeric keys)

● **Character keys**

If [Save Memo] is set to "ON" in the measurement settings, these appear when measured values are saved.

Reference

- "Character keys" (page 18)
 - "Save Memo" (page 97)
-



Fig. 9 Input screen example (character keys)

Main Unit Setup

Putting the valve stickers

If you use the manual measurement/calibration mode, it may be useful to put the valve stickers on the operation button panel as shown below.

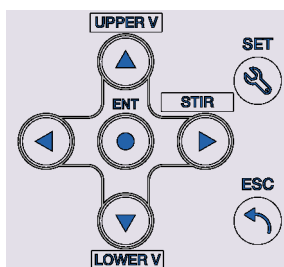

Fig. 10 Positions of the valve stickers

Placing the absorbent sheet

Follow the steps below to place the absorbent sheet on the tray in the main unit.

1. Turn OFF the power.
2. Open the right cover.
3. Place the absorbent sheet on the tray using tweezers.

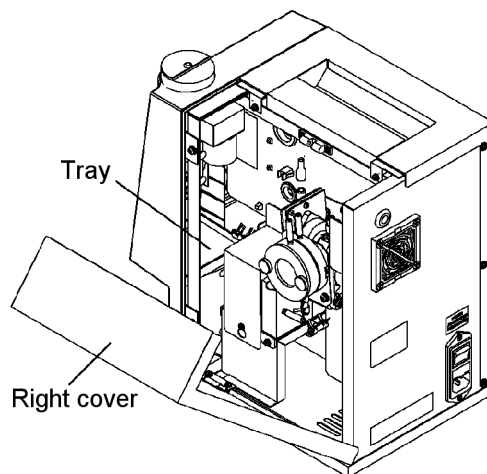

Fig. 11 Tray in the main unit

4. Close the right cover.

Basic Operation

Power ON



WARNING



Electric shock

To prevent electric shock, ground the product.
Do not ground the product to dangerous places such as a gas pipe.

1. Insert the provided power cable into the power cable connector on the back of the main unit.

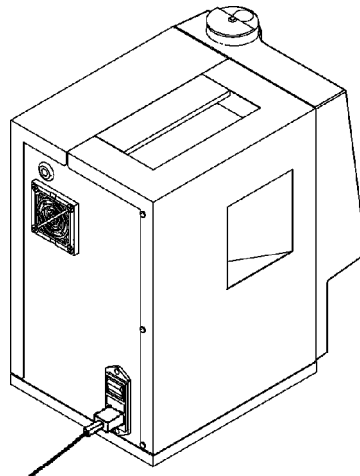

Fig. 12 Power cable connection

2. Turn the power ON, using the switch on the back of the main unit.
The power turns ON and the initial screen appears on the display followed by the Measurement Top screen. The warm-up icon blinks for 30 minutes.

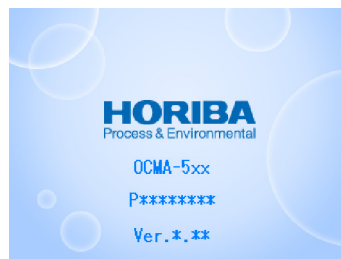

Fig. 13 Initial screen

Tip
The model, program number, and version that are shown on the initial screen vary by product.

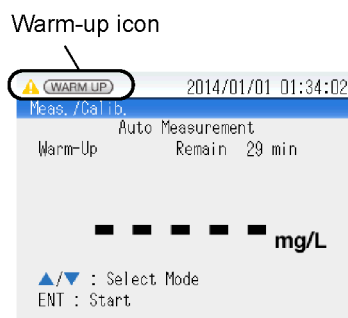

Fig. 14 Measurement Top screen

Note

- The main unit is not stable while the warm-up icon blinks. Although measurement is possible while the warm-up icon blinks, the alarm icon will blink after measurement is finished and an invalid data error will occur (refer to "Current Alarm screen" (page 71) and "Alarm displays and actions" (page 125)). For correct measurement, be sure to wait until the warm-up icon turns off before starting calibration or measurement.
- For high-precision measurement, warm up the analyzer at least an hour before calibration or measurement.

3. Refer to "System Setting screen" (page 103) to set the date and time.

Power OFF

1. Clean the flow paths inside the product.

Reference

"Rinsing the flow paths" (page 107)

2. Turn OFF the power switch.
3. Place the cap on the sample inlet.
4. Remove the power cable plug from the power outlet.
5. Dispose of the drainage liquid.

Reference

"Solvent S-316" (page 132)

Drainage mode operation

You can start liquid drainage manually by changing to the drainage mode. The procedure for draining liquid in the drainage mode is explained below.

1. **Press the up or down button with the Measurement Top screen appearing until the process display shows [Drainage].**
The drainage mode is entered.
2. **Press the ENT button.**
Liquid drainage starts.

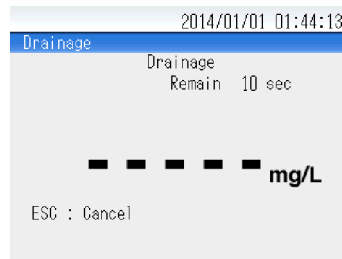

Fig. 15 Drainage mode - Drainage

When the set [Drainage Time] elapses, drainage ends and the Measurement Top screen returns.

Note

If an abnormal condition occurs during measurement, calibration, or liquid drainage, operation may stop. The alarm icon will blink. Check the alarm information on the Current Alarm screen (refer to "Current Alarm screen" (page 71) and "Alarm displays and actions" (page 125)).

Operations while the sequence is in progress

■ Pause

During measurement, the sequence can be paused in the automatic measurement mode, automatic zero calibration mode, and automatic span calibration mode.

1. **Press the ESC button during measurement.**
The sequence enters the paused state.
2. **To resume operation from the paused state, press the ENT button.**
Measurement will resume from the point where it was stopped.

Tip

If the ESC button is pressed in the paused state, the measurement is aborted and the measurement liquid is drained.

■ When an error occurs

When a light source error or unstable data alarm occurs, measurement stops, the Measurement Top screen returns, and the alarm icon blinks.

Reference

"Alarm displays and actions" (page 125)

Connecting a USB memory stick

This section explains how to connect a USB memory stick with the product.

When a USB memory stick is connected, the following operations can be performed.

- Saving the measurement history to a USB memory stick
- Saving the calibration history to a USB memory stick
- Saving the settings of the main unit to a USB memory stick

Note

- Some USB memory stick may not work with the OCMA.
Use a FAT/FAT32 formatted USB memory stick. Other formats may not be available with this product.
Even FAT/FAT32 formatted, some USB memory sticks may not work. In this case, try other type.
If you need the USB memory stick manufactured and verified by HORIBA Advanced Techno, contact your local dealer.
- Do not lose the cap for the USB memory port.
- When handling liquids during measurement, calibration, or otherwise, remove the USB memory stick from the USB memory port and cap the port. If a liquid spills on a USB memory stick or the USB memory port, the liquid may enter the interior of the product from the USB memory port and cause product damage.
- If any of the operations are attempted without inserting a USB memory stick into the USB memory port, a message of "Process has failed" will appear.
- For details on each of the operations, refer to "USB Memory screen" (page 74).

1. Remove the cap from the USB memory port on the left side of the product.
2. Insert the USB memory stick into the USB memory port.

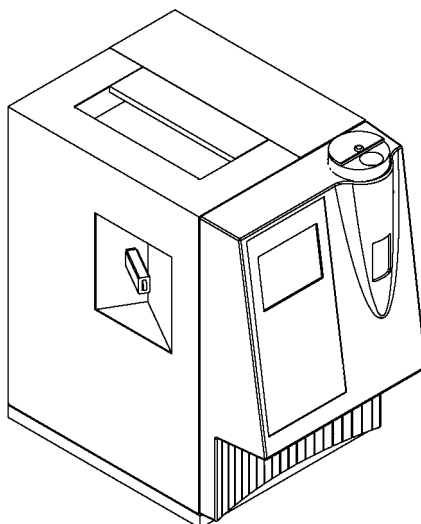

Fig. 16 Inserting a USB memory stick

The USB icon lights up on the screen.



Fig. 17 USB icon

Screen operations in the manual measurement/calibration mode

On the instantaneous value measurement screen, which appears when the manual measurement mode, manual zero calibration mode, or manual span calibration mode starts, you can switch to any operations below to control extraction, cell filling, measurement, and drain manually.

- Stirring motor: Rotate/stop the stirring blades inside the extraction tank.
- Fill cell valve: Start/stop flow from the extraction tank to the measurement cell.
- Drainage valve: Start/stop drainage from the measurement cell and extraction tank.

Reference

- "Meas. Mode" (page 92)
- "Calib. Mode" (page 102)
- "Manual measurement" (page 58)
- "Manual zero calibration" (page 30)
- "Manual span calibration" (page 32)

The procedure for performing operations with the instantaneous value measurement screen appearing is explained below.

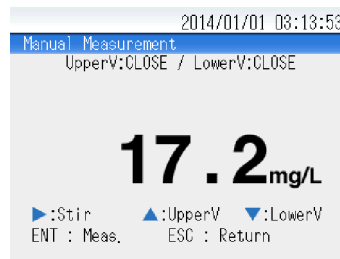







Fig. 18 Example of instantaneous value measurement screen (manual measurement)

The buttons and button functions, which can be used with the instantaneous value measurement screen appearing, are described in the table below.

Table 1 Operable buttons with the instantaneous value measurement screen

Button	Function
ENT button 	Starts measurement.
Up button 	Opens and closes the fill cell valve (UPPER V).
Down button 	Opens and closes the drainage valve (LOWER V).
Right button 	Switches the stirring motor ON and OFF (STIR).
ESC button 	Returns to the mode start state.

The relations between part control and product operation are shown in the table below.

Product operation	Stirring motor	Fill cell valve	Drainage valve
Extraction	ON	Closed	Closed
Cell filling	OFF	Open	Closed
Measurement	OFF	Open	Closed
Drainage (all)	OFF	Open	Open
Drainage (solvent)	OFF	Closed	Open

Using pop-up screens

A pop-up screen for selection or entry will appear when it is necessary for you to select an item or enter a number or characters when configuring settings or performing other operations. If [Save Memo] is set to "ON" in the measurement settings, a pop-up screen will appear for entering the data name, before measured values being saved.

The procedures for using the pop-up screens are explained below.

■ Selection list display

This screen is used to configure settings. Values that can be selected are shown in a list.

Reference

" Setting " (page 86)

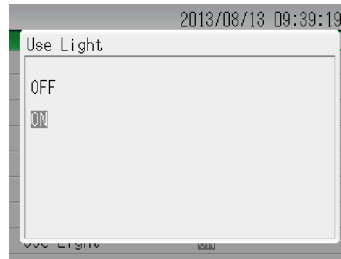

Fig. 19 Example of selection list pop-up screen

The buttons and button functions, which can be used with a selection list pop-up screen appearing, are described in the table below.

Table 2 Operable buttons with a selection list pop-up screen

Button		Function
ENT button		Applies the currently selected setting and closes the screen.
Up button		Selects the next item up.
Down button		Selects the next item down.
ESC button		Cancels changes and closes the screen.

Follow the steps below to change a setting.

1. Press the up or down button to select the desired value.
2. Press the ENT button.
The selected value is applied.

■ Numeric keys

This screen is used to configure settings. Numeric keys and an input box appear.

Reference

" Setting " (page 86)



Fig. 20 Example of numeric key pop-up screen

The buttons and button functions, which can be used with a numeric key pop-up screen appearing, are described in the table below.

Table 3 Operable buttons with a numeric key pop-up screen

Button		Function
ENT button		Applies the currently entered value and closes the screen.
Up button		Selects the next key up.
Down button		Selects the next key down.
Left button		Selects the next key to the left.
Right button		Selects the next key to the right.
ESC button		Cancels changes and closes the screen.

Follow the steps below to change a setting.

- 1. Press the up/down/left/right button to select a numeric key.**
The selected key is shown in red.
- 2. Press the ENT button.**
The selected value appears in the input box.
- 3. Repeat steps 1. to 2. to enter the desired numeric value in the input box.**
- 4. Press the up/down/left/right button to select the [ENT] key, and press the ENT button.**
The entered value, which appears in the input box, is applied.

■ Character keys

This screen is used to enter names of memo data such as measurement conditions. If [Save Memo] is set to "ON" in the measurement settings, this screen appears immediately before measured values are saved.

Reference

"Save Memo" (page 97)



Fig. 21 Example of character key pop-up screen

The buttons and button functions, which can be used with a character key pop-up screen appearing, are described in the table below.

Table 4 Operable buttons with a character key pop-up screen



Button		Function
ENT button		Applies the currently entered value and closes the screen.
Up button		Selects the next key up.
Down button		Selects the next key down.
Left button		Selects the next key to the left.
Right button		Selects the next key to the right.
ESC button		Cancels changes and closes the screen.

Follow the steps below to change a setting.

- 1. Press the up/down/left/right button to select a character key.**
The selected key is shown in red.
- 2. Press the ENT button.**
The selected character appears in the input box.
- 3. Repeat steps 1. to 2. to enter the desired characters in the input box.**
- 4. Press the up/down/left/right button to select the [ENT] key, and press the ENT button.**
The characters that appear in the input box are applied.

Preparation

Measurement preparation cautions

 CAUTION	
	Chemical hazard (solvent S-316) Inhalation or accidental ingestion of a large amount of solvent S-316 may be harmful. Observe the following rules when handling: <ul style="list-style-type: none">• Ventilate the work area sufficiently.• Wear a protective mask and protective gloves.• Wash hands well after handling the solvent.
	Chemical hazard (hydrochloric acid) Hydrochloric acid is toxic by skin or eye exposure. If it touches the skin, immediately rinse with water. If it reaches the eyes, rinse immediately under a large amount of running water and get medical attention.

To obtain correct measurement results, it is important to eliminate factors affecting measured values and to keep calibration and measurement conditions as uniform as possible. Observe the precautions below.

- Be sure to wash your hands before starting work. If oil from your fingers gets on the sample inlet on the product, the measuring utensils, or other parts, the measured value will be affected and correct measurement will be impossible.
- When measuring sample or reagent quantities, use suitable measuring utensils and measure accurately. When using a microsyringe or measuring syringe, take care that foam and bubbles are not drawn into the syringe. Foam and bubbles will increase measurement error.

In addition, read "Operational precautions" and "Solvent handling precautions" in the front matter of this manual.

Glassware

■ Items required

- Beakers (200 mL): 1 or 2 (for drainage)
- Measuring cylinders (20 mL) or syringes (20 mL, optional): 2 (for solvent and sample)
- Solvent S-316 (optional)
- Zero liquid for calibration (refer to "Zero liquid for calibration" (page 21))
- Span liquid for calibration (refer to "Span liquid for calibration" (page 21))
- Hydrochloric acid (refer to "Hydrochloric acid" (page 22))

■ Placing the beakers for drainage

Follow the steps below to place the drainage beakers.

1. Put tap water into the beakers so that the water level is approx. 1 cm from the bottom.
2. Place the beaker or beakers as shown below.

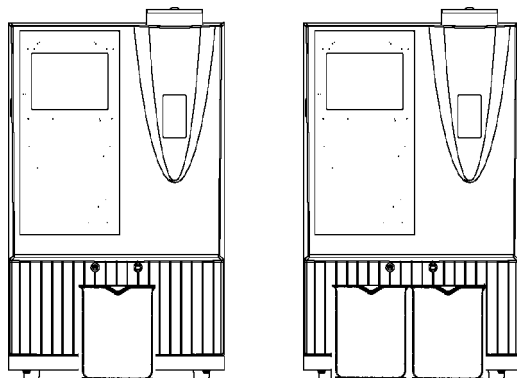

Fig. 22 Placing beakers for drainage

■ Cleaning the measuring cylinders or syringes

Clean the measuring cylinders or syringes (for solvent and for the sample) with pure solvent S-316.

Zero liquid for calibration

Prepare pure solvent S-316, the same as is used for measurement.

Span liquid for calibration

Use pure solvent S-316, the same as is used for measurement, to prepare the span liquid for calibration.

■ Using B-heavy oil

Use B-heavy oil (specific gravity 0.895 at 20°C) to prepare span liquid for OCMA-500. When you know the oil type to be measured, you can also use that oil type for the calibration oil.

● Items required

- Scale
- Glass container with a lid (screw-top bottle is recommended)
- Measuring flask
- Solvent S-316 (optional)
- B-heavy oil (specific gravity 0.895 at 20°C) or calibration oil (when the oil type to be measured is known)

Note

- Clean the glass utensils to be used with pure solvent S-316, and let them air dry completely. If the utensils cannot be dried completely, purge them 3 times or 4 times using solvent S-316.
- It is difficult to measure B-heavy oil with a microsyringe because it has a high viscosity. Use a suitably sized glass container with a lid (a screw-top bottle is recommended) for measurement.

● Preparation method

Prepare the liquid so that it has a concentration of approximately twice the measured value of the sample.

Tip

You can change the calibration value to be input as appropriate for the volume that is actually measured.

1. Use a scale to accurately measure the B-heavy oil in a glass container (with lid) of suitable size.
2. Transfer the B-heavy oil from the glass container to the measuring flask, while cleaning with S-316.
3. Fill the measuring flask to the graduation with solvent S-316.
4. Insert the stopper into the measuring flask and mix the contents well.

Table 5 Example of span liquid preparation

Calibration value (mg/L)	Concentration of span liquid (mg/L)	Measuring flask volume (mL)	B-heavy oil quantity (mg)
200	400	250	100
50	100	100	10
20	40	250	10

Hydrochloric acid

When an acid is added to a water sample containing organic matter, the solvent and the sample separate easily (salting-out effect).

When performing oil content extraction, the salting-out effect can be produced by adding approx. 6 mol/L hydrochloric acid.

The procedure for preparing 6 mol/L hydrochloric acid using commercially available concentrated hydrochloric acid (36%) is explained below.

■ Hydrochloric acid preparation method

● Items required

- Glass beaker
- Glass measuring utensil (measuring flask, measuring cylinder, etc.)
- Glass rod
- Pure water
- Commercially available concentrated hydrochloric acid (36%)

Note

Clean the glass utensils to be used with pure water, and let them air dry completely.

● Preparation method

1. Use a measuring cup to determine a specific volume of pure water and transfer it to the glass beaker.
2. Add the same volume (as the pure water) of commercially available hydrochloric acid, adding gradually by running the hydrochloric acid down the glass rod.

Note

Always add the hydrochloric acid to the pure water. Do not pour in the hydrochloric acid all at once. Using an incorrect preparation method may cause heat generation and explosive boiling.

Condition settings

Standard calibration conditions and measurement conditions are set by default in the product. Once the warm-up icon has turned off, calibration and measurement can be started immediately.

■ Calibration condition settings

The default settings for the calibration conditions and the pages to refer to for the setting procedures are shown below.

Measurement condition	Default setting	Setting procedure page
Span Point	200.0 mg/L	"Span Point" (page 100)
Extraction Time	40 sec	"Extraction Time" (page 100)
Separation Time	30 sec	"Separation Time" (page 101)
Number of Purge	2 time	"Number of Purge" (page 101)
Calib. Mode	AUTO	"Calib. Mode" (page 102)
Calib. Point	1point	"Calib. Point" (page 102)
Calib. Curve	-	"Calib. Curve" (page 102)





■ Measurement condition settings

The default settings for the measurement conditions and the pages to refer to for the setting procedures are shown below.

Measurement condition	Default setting	Setting procedure page
Extraction Time	40 sec	"Extraction Time" (page 89)
Separation Time	30 sec	"Separation Time" (page 89)
Fill Cell Time	60 sec	"Fill Cell Time" (page 90)
Meas. Limit Time	300 sec	"Meas. Limit" (page 90)
Drainage Time	30 sec	"Drainage Time" (page 91)
Number of Purge	2 time	"Number of Purge" (page 91)
Meas. Mode	AUTO	"Meas. Mode" (page 92)
Measurement Unit	mg/L	"Measurement Unit" (page 92)
Solvent Vol.	8.0 mL	"Solvent Vol." (page 93)
Sample Vol.	16.0 mL	"Sample Vol." (page 94)
Conc. Correction	1.0	"Conc. Correction" (page 95)
Zero Shift Value	0.0 mg/L	"Zero Shift Value" (page 96)
Use Light	ON	"Use Light" (page 96)
Confirm Save	AUTO	"Confirm Save" (page 97)
Save Memo	OFF	"Save Memo" (page 97)
Display Negative	OFF	"Display Negative" (page 98)
Display Raw Data	OFF	"Display Raw Data" (page 98)

Calibration

Calibration cautions

 CAUTION	
	<p>Chemical hazard (solvent S-316) Inhalation or accidental ingestion of a large amount of solvent S-316 may be harmful. Observe the following rules when handling:</p> <ul style="list-style-type: none"> • Ventilate the work area sufficiently. • Wear a protective mask and protective gloves. • Wash hands well after handling the solvent.
	<p>Chemical hazard (hydrochloric acid) Hydrochloric acid is toxic by skin or eye exposure. If it touches the skin, immediately rinse with water. If it reaches the eyes, rinse immediately under a large amount of running water and get medical attention.</p>
	<p>When dispensing liquids into the extraction tank, limit the solvent amount to 10 mL or less and the amount of the measurement liquid to 20 mL or less, so that the total volume of liquid does not exceed the upper limit line (30 mL). If the liquid exceeds the upper limit line, the liquid may leak and cause short-circuit in the internal wiring of the product. If liquid containing hydrochloric acid leaks and comes in contact with the skin, irritation and burning may occur.</p>
	<p>Discard the liquid collected in the beakers before overflow. If liquid containing hydrochloric acid overflows and comes in contact with the skin, irritation and burning may occur.</p>

To obtain correct measurement results, it is important to eliminate factors affecting measured values and to keep calibration and measurement conditions as uniform as possible. Observe the precautions below.

- If the temperature of the measurement liquid or solvent is lower than the inside of the main unit, condensation may form inside the main unit and the indicated value may be unsteady or shift.
 If the room temperature is less than 5°C, the viscosity of solvent S-316 will increase and the indicated value may be low. In this case, raise the room temperature above 5°C, or set [Fill Cell Time] to a longer value.
- Avoid performing measurement at high temperature and high humidity. Moisture may cause the indicated value to shift.
- When the air has a high concentration of hydrocarbons, for instance in an oil refinery, hydrocarbons may be adsorbed inside the product and affect measurement. In this type of location, increase the [Number of Purge] value.
- Be sure to wash your hands before starting work. If oil from your fingers gets on the sample inlet on the product, the measuring utensils, or other parts, the measured value will be affected and correct measurement will be impossible.
- Perform measurement with the right cover closed. Measurement cannot be stable with the right cover open.
- Be sure to perform zero calibration before every measurement. Perform span calibration from once a day to once a week. When you change to a new solvent lot, perform zero calibration and span calibration before measurement using the calibration liquids prepared from the new lot of solvent.
- Be sure to perform zero calibration before performing span calibration. If zero calibration is performed after span calibration, correct measurement will be impossible .

-
- Purging is necessary to prevent effects from the previous measurement liquid. Set [Number of Purge] from 2 to 6. If the concentration changes by 100 mg/L or more from the previous measurement, set [Number of Purge] to 5 or more.
 - When using the built-in extractor, maintain an extraction ratio of solvent:water = 1:2. The instructions in this manual indicate 8 mL of solvent and 16 mL of clean water or sample water to provide an extraction ratio of solvent:water = 1:2.
 - When the built-in extractor is not used, the extraction ratio can be changed. However, be sure to keep the solvent to sample water extraction ratio the same between measurement and calibration. If the extraction ratios are not the same, measurement error will occur due to the differences in the water content of the solvent. In addition, this product is designed for measurement at an extraction ratio of solvent:sample water = 1:2. Other extraction ratios may cause greater measurement error and the specified product performance cannot be guaranteed.
 - When measuring sample or reagent quantities, use suitable measuring utensils and measure accurately. When using a microsyringe or measuring syringe, take care that foam and bubbles are not drawn into the syringe. Foam and bubbles will increase measurement error.
 - Dispense liquid slowly into the extraction tank. A vigorous dispense of liquid may cause overflow.
 - If an abnormality occurs during measurement, calibration, or liquid drainage, operation may stop. The alarm icon will blink. Check the alarm information on the Current Alarm screen (refer to "Current Alarm screen" (page 71) and "Alarm displays and actions" (page 125)).

In addition, read "Operational precautions" and "Solvent handling precautions" in the front matter of this manual.

Points to check prior to calibration

■ Points to check prior to zero calibration

Is the warm-up icon off?	If the warm-up icon is blinking, wait until it turns off.
Is the alarm icon off?	If the alarm icon is blinking, check the error information and remove the cause (refer to "List of alarms" (page 125)).
Are the beakers for drainage in place?	If not, set the beakers for drainage in place (refer to "Placing the beakers for drainage" (page 20)).

■ Points to check prior to span calibration

Did you perform zero calibration?	If not, first perform zero calibration.
Is the warm-up icon off?	If the warm-up icon is blinking, wait until it turns off.
Is the alarm icon off?	If the alarm icon is blinking, check the error information and remove the cause (refer to "List of alarms" (page 125)).
Are the beakers for drainage in place?	If not, set the beakers for drainage in place (refer to "Placing the beakers for drainage" (page 20)).

Items required

■ Zero calibration

- OCMA-500 (this product)
- Measuring cylinders (20 mL) or syringes (20 mL, optional): 2 (for solvent and sample)
- Dropper (provided): 1 (for hydrochloric acid)
- Zero liquid for calibration (refer to "Zero liquid for calibration" (page 21))
- Hydrochloric acid (refer to "Hydrochloric acid" (page 22))
- Clean water*

■ Span calibration

- OCMA-500 (this product)
- Measuring cylinders (20 mL) or syringes (20 mL, optional): 2 (for solvent and sample)
- Dropper (provided): 1 (for hydrochloric acid)
- Span liquid for calibration (refer to "Span liquid for calibration" (page 21))
- Hydrochloric acid (refer to "Hydrochloric acid" (page 22))
- Clean water*

Note

- *: Use the same clean water for the sequence of tasks from zero calibration to measurement.
- It is recommended that pure water is used.
 - When the sample to be measured contains large amounts of water-soluble substances, such as urea or NaCl, and the concentration is known, perform zero calibration using that oil-free aqueous solution.
 - When water is not used for measurement, such as when measuring the oil content of metal parts, do not use clean water for zero calibration (do not perform step 5. (page 27)) of the zero calibration procedure).
-

Automatic zero calibration

1. Set the calibration mode to "AUTO" on the Calibration Setting screen.
Change other settings as needed.

Reference

- "Calibration condition settings" (page 23)
- "Calibration Setting screen" (page 99)

2. Press the CAL button or up/down button with the Measurement Top screen appearing until the process display shows [Auto Zero Calibration].
The automatic zero calibration mode is entered.



Fig. 23 Start of the automatic zero calibration mode

3. Use the measuring cylinder or measuring syringe (for solvent) to dispense 8 mL of zero liquid for calibration through the sample inlet.
4. Use the dropper to add one drop of hydrochloric acid through the sample inlet.
5. Use the measuring cylinder or measuring syringe (for sample) to dispense 16 mL of clean water through the sample inlet.
6. Press the ENT button.

If the set [Number of Purge] has not been completed:

The purge sequence starts. The screen title changes to [Auto Zero Calibration (Purge: 1)], and the process display changes as follows as the sequence progresses:

[Extraction] → [Layer Separation] → [Fill Cell] → [Drainage]

The remaining time of the current process is shown (counting down).

When the purge sequence ends, the start state of the automatic zero calibration mode returns.

When the remaining [Number of Purge] is 0:

The measurement sequence starts. The screen title changes to [Auto Zero Calibration: Measurement], and the process display changes as follows as the sequence progresses:

[Extraction] → [Layer Separation] → [Fill Cell] → [Calibration]

The remaining time of the current process is shown (counting down) during extraction, layer separation, and cell filling. The elapsed time is shown (counting up) during calibration. When calibration ends, the calibration result appears.

After the result appears, the measurement liquid is drained. During drainage, the process display on the screen shows [Drainage].

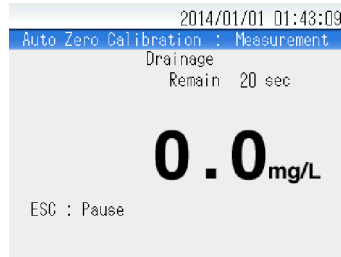

Fig. 24 Display of automatic zero calibration result

When drainage is completed, the start state of the automatic zero calibration mode returns.

7. Repeat steps 3. to 6. until the set [Number of Purge] is completed and measurement starts.

Automatic span calibration

1. Set the calibration mode to "AUTO" on the Calibration Setting screen.
Change other settings as needed.

Note

The value set in [Span Point] in the calibration settings must be adjusted based on the extraction ratio.
For example, when the extraction ratio is solvent:water = 1:2, set 1/2 the value of the actual concentration of the span liquid for calibration in [Span Point] in the calibration settings.

Reference

- "Calibration condition settings" (page 23)
- "Calibration Setting screen" (page 99)

2. Press the CAL button or up/down button with the Measurement Top screen appearing until the process display shows [Auto Span Calibration].
The automatic span calibration mode is entered.

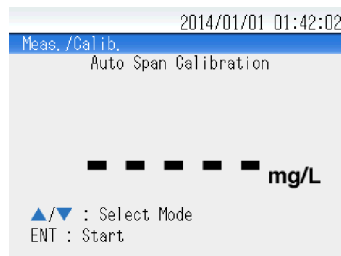

Fig. 25 Start of the automatic span calibration mode

3. Use the measuring cylinder or measuring syringe (for solvent) to dispense 8 mL of span liquid for calibration through the sample inlet.
4. Use the dropper to add one drop of hydrochloric acid through the sample inlet.
5. Use the measuring cylinder or measuring syringe (for sample) to dispense 16 mL of clean water through the sample inlet.

6. Press the ENT button.

If the set [Number of Purge] has not been completed:

The purge sequence starts. The screen title changes to [Auto Span Calibration (Purge: 1)], and the process display changes as follows as the sequence progresses:

[Extraction] → [Layer Separation] → [Fill Cell] → [Drainage]

The remaining time of the current process is shown (counting down).

When the purge sequence ends, the start state of the automatic span calibration mode returns.

When the remaining [Number of Purge] is 0:

The measurement sequence starts. The screen title changes to [Auto Span Calibration: Measurement] and the process display changes as follows as the sequence progresses:

[Extraction] → [Layer Separation] → [Fill Cell] → [Calibration]

The remaining time of the current process is shown (counting down) during extraction, layer separation, and cell filling. The elapsed time is shown (counting up) during calibration. When calibration ends, the calibration result appears.

After the result appears, the measurement liquid is drained. During drainage, the process display on the screen shows [Drainage].

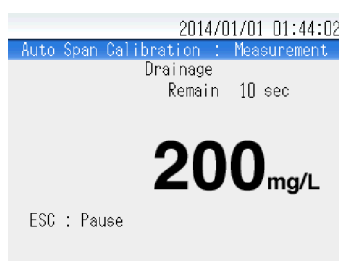

Fig. 26 Display of automatic span calibration result

When drainage is completed, the start state of the automatic span calibration mode returns.

7. Repeat steps 3. to 6. until the set [Number of Purge] is completed and measurement starts.

Manual zero calibration

1. Set the calibration mode to "MANUAL" on the Calibration Setting screen.
Change other settings as needed.

Reference

- "Calibration condition settings" (page 23)
- "Calibration Setting screen" (page 99)

2. Press the CAL button or up/down button with the Measurement Top screen appearing until the process display shows [Manual Zero Calibration].
The manual zero calibration mode is entered.

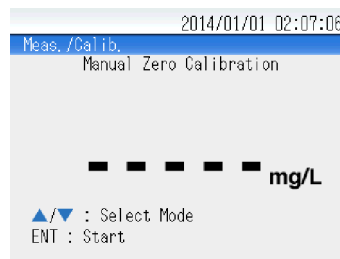

Fig. 27 Start of the manual zero calibration mode

3. Use the measuring cylinder or measuring syringe (for solvent) to dispense 8 mL of zero liquid for calibration through the sample inlet.
4. Use the dropper to add one drop of hydrochloric acid through the sample inlet.
5. Use the measuring cylinder or measuring syringe (for sample) to dispense 16 mL of clean water through the sample inlet.
6. Press the ENT button.

The instantaneous value measurement screen appears.

The screen title shows [Manual Zero Calibration], and the process display shows the current status of the valves.

The operation guide display shows the stirring motor and valve operation buttons and [ENT: Calib. ESC: Return].

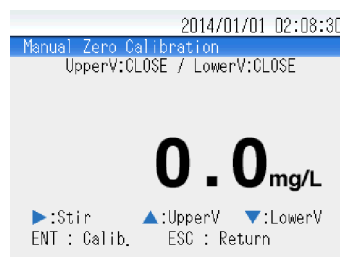

Fig. 28 Manual zero calibration - Instantaneous value measurement

7. If needed, execute purging (extraction, cell filling, and drainage) referring to "Screen operations in the manual measurement/calibration mode" (page 14).
8. Execute extraction and fill the cell at any time referring to steps 3. to 6. and "Screen operations in the manual measurement/calibration mode" (page 14).

9. Press the ENT button.

Measurement starts. The operation guide display shows [ESC: Cancel].

The elapsed time is shown (counting up). When measurement ends, the calibration result appears.

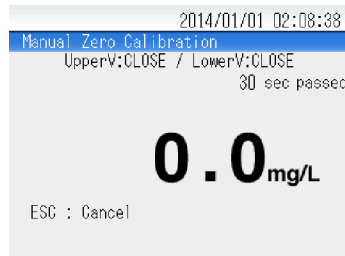

Fig. 29 Manual zero calibration - Measurement

When measurement ends normally, the measured value is held.

The operation guide display shows [ESC: Return].

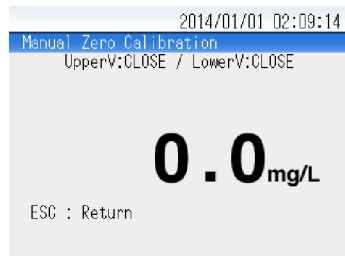

Fig. 30 Manual zero calibration - Result

10. Press the ESC button.

The instantaneous value measurement screen returns.

11. Execute drainage referring to "Screen operations in the manual measurement/calibration mode" (page 14) at any time.**12. Press the ESC button.**

The start state of the manual zero calibration mode returns.

Manual span calibration

1. Set the calibration mode to "MANUAL" on the Calibration Setting screen.
Change other settings as needed.

Note

The value set in [Span Point] in the calibration settings must be adjusted based on the extraction ratio.

For example, when the extraction ratio is solvent:water = 1:2, set 1/2 the value of the actual concentration of the span liquid for calibration in [Span Point] in the calibration settings.

Reference

- "Calibration condition settings" (page 23)
- "Calibration Setting screen" (page 99)

2. Press the CAL button or up/down button with the Measurement Top screen appearing until the process display shows [Manual Span Calibration].
The manual span calibration mode is entered.

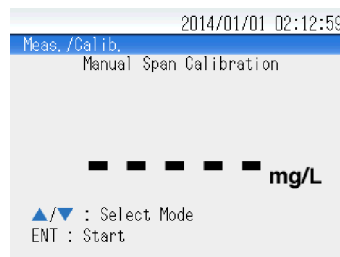

Fig. 31 Start of the manual span calibration mode

3. Use the measuring cylinder or measuring syringe (for solvent) to dispense 8 mL of span liquid for calibration through the sample inlet.
4. Use the dropper to add one drop of hydrochloric acid through the sample port.
5. Use the measuring cylinder or measuring syringe (for sample) to dispense 16 mL of clean water through the sample inlet.
6. Press the ENT button.

The instantaneous value measurement screen appears.

The screen title shows [Manual Span Calibration] and the process display shows the current status of the valves.

The operation guide display shows the stirring motor and valve operation buttons and [ENT: Calib. ESC: Return].

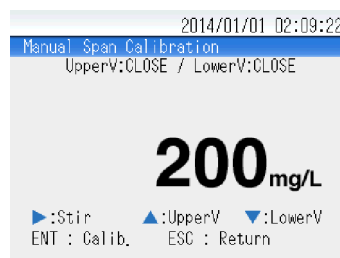

Fig. 32 Manual span calibration - Instantaneous value measurement

7. If needed, execute purging (extraction, cell filling, and drainage) referring to "Screen operations in the manual measurement/calibration mode" (page 14).
8. Execute extraction and fill the cell at any time referring to steps 3. to 6. and "Screen operations in the manual measurement/calibration mode" (page 14).
9. Press the ENT button.
Measurement starts. The operation guide display shows [ESC: Cancel].
The elapsed time is shown (counting up). When measurement ends, the calibration result appears.

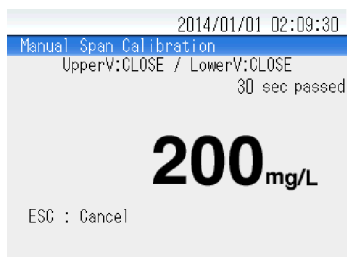

Fig. 33 Manual span calibration - Measurement

When measurement ends normally, the measured value is held.
The operation guide display shows [ESC: Return].

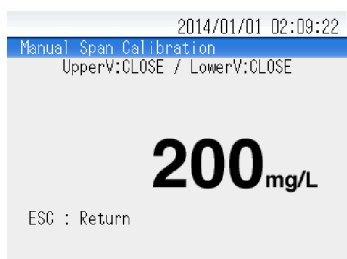







Fig. 34 Manual span calibration - Result

10. Press the ESC button.
The instantaneous value measurement screen returns.
11. Execute drainage referring to "Screen operations in the manual measurement/calibration mode" (page 14) at any time.
12. Press the ESC button.
The start state of the manual span calibration mode returns.

Calibration (ASTM D7066-4)

Calibration cautions

 CAUTION	
	<p>Chemical hazard (solvent S-316)</p> <p>Inhalation or accidental ingestion of a large amount of solvent S-316 may be harmful. Observe the following rules when handling:</p> <ul style="list-style-type: none"> • Ventilate the work area sufficiently. • Wear a protective mask and protective gloves. • Wash hands well after handling the solvent.
	<p>Chemical hazard (hydrochloric acid)</p> <p>Hydrochloric acid is toxic by skin or eye exposure. If it touches the skin, immediately rinse with water. If it reaches the eyes, rinse immediately under a large amount of running water and get medical attention.</p>
	<p>When dispensing liquids into the extraction tank, limit the solvent amount to 10 mL or less and the amount of the measurement liquid to 20 mL or less, so that the total volume of liquid does not exceed the upper limit line (30 mL). If the liquid exceeds the upper limit line, the liquid may leak and cause short-circuit in the internal wiring of the product. If liquid containing hydrochloric acid leaks and comes in contact with the skin, irritation and burning may occur.</p>
	<p>Discard the liquid collected in the beakers before overflow. If liquid containing hydrochloric acid overflows and comes in contact with the skin, irritation and burning may occur.</p>

To obtain correct measurement results, it is important to eliminate factors affecting measured values and to keep calibration and measurement conditions as uniform as possible. Observe the precautions below.

- If the temperature of the measurement liquid or solvent is lower than the inside of the main unit, condensation may form inside the main unit and the indicated value may be unsteady or shift.
If the room temperature is less than 5°C, the viscosity of solvent S-316 will increase and the indicated value may be low. In this case, raise the room temperature above 5°C, or set [Fill Cell Time] to a longer value.
- Avoid performing measurement at high temperature and high humidity. Moisture may cause the indicated value to shift.
- When the air has a high concentration of hydrocarbons, for instance in oil refinery, hydrocarbons may be adsorbed inside the product and affect measurement. In this type of location, increase the [Number of Purge] value.
- Be sure to wash your hands before starting work. If oil from your fingers gets on the sample inlet on the product, the measuring utensils, or other parts, the measured value will be affected and correct measurement will be impossible.
- Perform measurement with the right cover closed. Measurement cannot be stable with the right cover open.
- Be sure to perform zero calibration before every measurement. Perform span calibration from once a day to once a week. When you change to a new solvent lot, perform zero calibration and span calibration before measurement using the calibration liquids prepared from the new lot of solvent.

-
- Be sure to perform zero calibration before performing span calibration. If zero calibration is performed after span calibration, correct measurement will be impossible.
 - Purging is necessary to prevent effects from the previous measurement liquid. Set [Number of Purge] to a value from 2 to 6. If the concentration changes by 100 mg/L or more from the previous measurement, set [Number of Purge] to 5 or more.
 - When using the built-in extractor, maintain an extraction ratio of solvent:water = 1:2. The instructions in this manual indicate 8 mL of solvent and 16 mL of clean water or sample water to provide an extraction ratio of solvent:water = 1:2.
 - When the built-in extractor is not used, the extraction ratio can be changed. However, be sure to keep the solvent to sample water extraction ratio the same between measurement and calibration. If the extraction ratios are not the same, measurement error will occur due to the differences in the water content of the solvent. In addition, this product is designed for measurement at an extraction ratio of solvent:sample water = 1:2. Other extraction ratios may cause greater measurement error and the specified product performance cannot be guaranteed.
 - When measuring sample or reagent quantities, use suitable measuring utensils and measure accurately. When using a microsyringe or measuring syringe, take care that foam and bubbles are not drawn into the syringe. Foam and bubbles will increase measurement error.
 - Dispense liquid slowly into the extraction tank. A vigorous dispense of liquid may cause overflow.
 - If an abnormality occurs during measurement, calibration, or liquid drainage, operation may stop. The alarm icon will blink. Check the alarm information on the Current Alarm screen (refer to "Current Alarm screen" (page 71) and "Alarm displays and actions" (page 125)).

In addition, read "Operational precautions" and "Solvent handling precautions" in the front matter of this manual.

Points to check prior to calibration

■ Points to check prior to zero calibration

Is the warm-up icon off?	If the warm-up icon is blinking, wait until it turns off.
Is the alarm icon off?	If the alarm icon is blinking, check the error information and remove the cause (refer to "List of alarms" (page 125)).
Are the beakers for drainage in place?	If not, set the beakers for drainage in place (refer to "Placing the beakers for drainage" (page 20)).

■ Points to check prior to span calibration

Did you perform zero calibration?	If not, first perform zero calibration.
Is the warm-up icon off?	If the warm-up icon is blinking, wait until it turns off.
Is the alarm icon off?	If the alarm icon is blinking, check the error information and remove the cause (refer to "List of alarms" (page 125)).
Are the beakers for drainage in place?	If not, set the beakers for drainage in place (refer to "Placing the beakers for drainage" (page 20)).

Items required

■ Zero calibration

- OCMA-500 (this product)
- Measuring cylinders (20 mL) or syringes (20 mL, optional): 2 (for solvent and sample)
- Dropper (provided): 1 (for hydrochloric acid)
- Zero liquid for calibration (refer to "Zero liquid for calibration" (page 37))
- Hydrochloric acid (refer to "Hydrochloric acid" (page 38))
- Clean water*

■ Span calibration

- OCMA-500 (this product)
- Measuring cylinders (20 mL) or syringes (20 mL, optional): 2 (for solvent and sample)
- Dropper (provided): 1 (for hydrochloric acid)
- Span liquid for calibration (refer to "Span liquid for calibration" (page 37))
- Hydrochloric acid (refer to "Hydrochloric acid" (page 38))
- Clean water*

Note

- *: Use the same clean water for the sequence of tasks from zero calibration to measurement.
- It is recommended that pure water is used.
 - When the sample to be measured contains large amounts of water-soluble substances, such as urea or NaCl, and the concentration is known, perform zero calibration using that oil-free aqueous solution.
 - When water is not used for measurement, such as when measuring the oil content of metal parts, do not use clean water for zero calibration (do not perform step 6. (page 39) of the zero calibration procedure).

Zero liquid for calibration

Prepare pure solvent S-316, the same as is used for measurement.

Span liquid for calibration

Use pure solvent S-316, the same as is used for measurement, to prepare the span liquid for calibration.

For details of calibration, please refer to the original text of ASTM D7066-4.

● Items required

- Microsyringe (25 μL , optional): 1
- Measuring flask
- Solvent S-316 (optional)
- Calibration oil described in ASTM D7066-4

Note

- Clean the glass utensils to be used with pure solvent S-316, and , purge them 3 times or 4 times using solvent S-316.
-

● Preparation method

1. Draw the calibration oil into the microsyringe and transfer to the measuring flask.
2. Fill the measuring flask to the graduation with solvent S-316.
3. Insert the stopper into the measuring flask and mix the contents well.

Hydrochloric acid

When an acid is added to a water sample containing organic matter, the solvent and the sample separate easily (salting-out effect).

When performing oil content extraction, the salting-out effect can be produced by adding approx. 6 mol/L hydrochloric acid.

The procedure for preparing 6 mol/L hydrochloric acid using commercially available concentrated hydrochloric acid (36%) is explained below.

■ Hydrochloric acid preparation method

● Items required

- Glass beaker
- Glass measuring utensil (measuring flask, measuring cylinder, etc.)
- Glass rod
- Pure water
- Commercially available concentrated hydrochloric acid (36%)

Note

Clean the glass utensils to be used with pure water, and let them air dry completely.

● Preparation method

1. Use a measuring cup to determine a specific volume of pure water and transfer it to the glass beaker.
2. Add the same volume (as the pure water) of commercially available hydrochloric acid, adding gradually by running the hydrochloric acid down the glass rod.

Note

Always add the hydrochloric acid to the pure water. Do not pour in the hydrochloric acid all at once. Using an incorrect preparation method may cause heat generation and explosive boiling.

Automatic zero calibration

1. Set the calibration point to "5 point" on the Calibration Setting screen.
2. Set the calibration mode to "AUTO" on the Calibration Setting screen.
Change other settings as needed.

Reference

- "Calibration condition settings" (page 23)
- "Calibration Setting screen" (page 99)

3. Press the CAL button or up/down button with the Measurement Top screen appearing until the process display shows [Auto Zero Calibration].
The automatic zero calibration mode is entered.



Fig. 35 Start of the automatic zero calibration mode

4. Use the measuring cylinder or measuring syringe (for solvent) to dispense 8 mL of zero liquid for calibration through the sample inlet.
5. Use the dropper to add one drop of hydrochloric acid through the sample inlet.
6. Use the measuring cylinder or measuring syringe (for sample) to dispense 16 mL of clean water through the sample inlet.
7. Press the ENT button.

If the set [Number of Purge] has not been completed:

The purge sequence starts. The screen title changes to [Auto Zero Calibration (Purge: 1)], and the process display changes as follows as the sequence progresses:

[Extraction] → [Layer Separation] → [Fill Cell] → [Drainage]

The remaining time of the current process is shown (counting down).

When the purge sequence ends, the start state of the automatic zero calibration mode returns.

When the remaining [Number of Purge] is 0:

The measurement sequence starts. The screen title changes to [Auto Zero Calibration: Measurement], and the process display changes as follows as the sequence progresses:

[Extraction] → [Layer Separation] → [Fill Cell] → [Calibration]

The remaining time of the current process is shown (counting down) during extraction, layer separation, and cell filling. The elapsed time is shown (counting up) during calibration. When calibration ends, the calibration result appears.

After the result appears, the measurement liquid is drained. During drainage, the process display on the screen shows [Drainage].

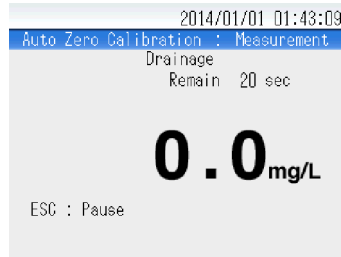

Fig. 36 Display of automatic zero calibration result

When drainage is completed, the start state of the automatic zero calibration mode returns.

8. Repeat steps 3. to 6. until the set [Number of Purge] is completed and measurement starts.

Automatic span calibration

1. Set the calibration point to “5 point” on the Calibration Setting screen.
2. Set the calibration mode to “AUTO” on the Calibration Setting screen.
Change other settings as needed.
3. Set the span point 1 to 5 on the Calibration Setting screen.

Note

- The value set in [Span Point] in the calibration settings must be adjusted based on the extraction ratio.
For example, when the extraction ratio is solvent:water = 1:2, set 1/2 the value of the actual concentration of the span liquid for calibration in [Span Point] in the calibration settings.
- Set the span point increases from the span point 1 to the span point 5.
The initial settings for span point 1 to 5 are 40 mg/L, 80 mg/L, 120 mg/L, 160 mg/L, and 200 mg/L.

Reference

- "Calibration condition settings" (page 23)
- "Calibration Setting screen" (page 99)

4. Press the CAL button or up/down button with the Measurement Top screen appearing until the process display shows [Auto 1st Span].
The automatic span calibration (1st to 5th point) mode is entered.

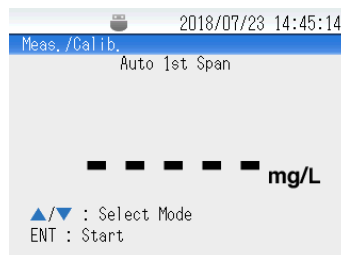

Fig. 37 Start of the automatic span calibration (1st to 5th point) mode

5. Use the measuring cylinder or measuring syringe (for solvent) to dispense 8 mL of span liquid for calibration through the sample inlet.

6. Use the dropper to add one drop of hydrochloric acid through the sample inlet.
7. Use the measuring cylinder or measuring syringe (for sample) to dispense 16 mL of clean water through the sample inlet.
8. Press the ENT button.

If the set [Number of Purge] has not been completed:

The purge sequence starts. The screen title changes to [Auto 1st Span (Purge: 1)], and the process display changes as follows as the sequence progresses:

[Extraction] → [Layer Separation] → [Fill Cell] → [Drainage]

The remaining time of the current process is shown (counting down).

When the purge sequence ends, the start state of the automatic span calibration (1st to 5th point) mode returns.

When the remaining [Number of Purge] is 0:

The measurement sequence starts. The screen title changes to [Auto 1st Span: Measurement] and the process display changes as follows as the sequence progresses:

[Extraction] → [Layer Separation] → [Fill Cell] → [Calibration]

The remaining time of the current process is shown (counting down) during extraction, layer separation, and cell filling. The elapsed time is shown (counting up) during calibration. When calibration ends, the calibration result appears.

After the result appears, the measurement liquid is drained. During drainage, the process display on the screen shows [Drainage].



Fig. 38 Display of automatic span point 1 result

When drainage is completed, the start state of the automatic span calibration (1st to 5th point) mode returns.

9. Repeat steps 3. to 6. until the set [Number of Purge] is completed and measurement starts.

10. As with auto 1st span, please also calibrate the auto 2nd span to the 5th span.

Tip

Unnecessary span points can be invalidated from the Calibration Setting .

The span point value is red color in the initial setting, but it changes to black color by performing calibration.

Span points return to red color by changing the span point value or turning it invalid after calibration, but it will turn to black color by turning it to original span point value again.

Note

RSD (coefficient of variation) is calculated from the result of 1st to 5th span calibration.

In the case of $RSD < 15\%$ and $RSD \geq 15\%$, how to draw the calibration curve changes (For details, see original text of ASTM standard).

RSD can not be calculated if the span point is invalidated by three or more points.

In the case of $RSD \geq 15\%$, the concentration of the prepared span solution may be different from the set span point value.

Manual zero calibration

1. Set the calibration point to "5 point" on the Calibration Setting screen.
2. Set the calibration mode to "MANUAL" on the Calibration Setting screen.
Change other settings as needed.

Reference

- "Calibration condition settings" (page 23)
- "Calibration Setting screen" (page 99)

3. Press the CAL button or up/down button with the Measurement Top screen appearing until the process display shows [Manual Zero Calibration].
The manual zero calibration mode is entered.

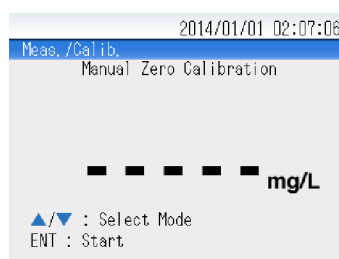

Fig. 39 Start of the manual zero calibration mode

4. Use the measuring cylinder or measuring syringe (for solvent) to dispense 8 mL of zero liquid for calibration through the sample inlet.
5. Use the dropper to add one drop of hydrochloric acid through the sample inlet.
6. Use the measuring cylinder or measuring syringe (for sample) to dispense 16 mL of clean water through the sample inlet.
7. Press the ENT button.
The instantaneous value measurement screen appears.
The screen title shows [Manual Zero Calibration], and the process display shows the current status of the valves.
The operation guide display shows the stirring motor and valve operation buttons and [ENT: Calib. ESC: Return].

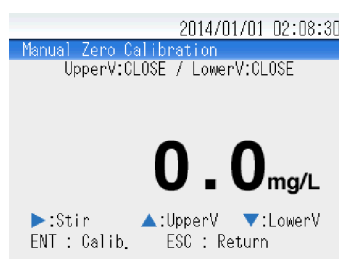

Fig. 40 Manual zero calibration - Instantaneous value measurement

8. If needed, execute purging (extraction, cell filling, and drainage) referring to "Screen operations in the manual measurement/calibration mode" (page 14).
9. Execute extraction and fill the cell at any time referring to steps 3. to 6. and "Screen operations in the manual measurement/calibration mode" (page 14).

10. Press the ENT button.

Measurement starts. The operation guide display shows [ESC: Cancel].

The elapsed time is shown (counting up). When measurement ends, the calibration result appears.

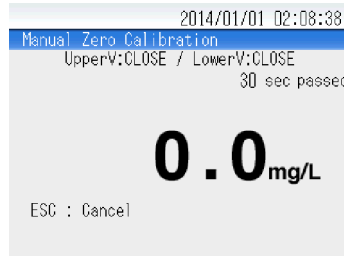

Fig. 41 Manual zero calibration - Measurement

When measurement ends normally, the measured value is held.

The operation guide display shows [ESC: Return].

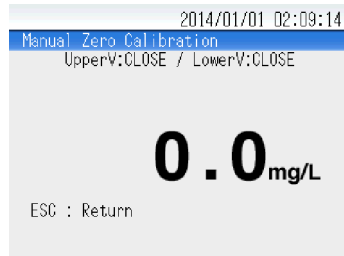

Fig. 42 Manual zero calibration - Result

11. Press the ESC button.

The instantaneous value measurement screen returns.

12. Execute drainage referring to "Screen operations in the manual measurement/calibration mode" (page 14) at any time.

13. Press the ESC button.

The start state of the manual zero calibration mode returns.

Manual span calibration

1. Set the calibration point to "5 point" on the Calibration Setting screen.
2. Set the calibration mode to "MANUAL" on the Calibration Setting screen. Change other settings as needed.
3. Set the span point 1 to 5 on the Calibration Setting screen.

Note

- The value set in [Span Point] in the calibration settings must be adjusted based on the extraction ratio.
For example, when the extraction ratio is solvent:water = 1:2, set 1/2 the value of the actual concentration of the span liquid for calibration in [Span Point] in the calibration settings.
- Set the span point increases from the span point 1 to the span point 5.
The initial settings for span point 1 to 5 are 40 mg/L, 80 mg/L, 120 mg/L, 160 mg/L, and 200 mg/L respectively.

Reference

- "Calibration condition settings" (page 23)
- "Calibration Setting screen" (page 99)

4. Press the CAL button or up/down button with the Measurement Top screen appearing until the process display shows [Manual 1st Span].
The manual span calibration (1st to 5th point) mode is entered.

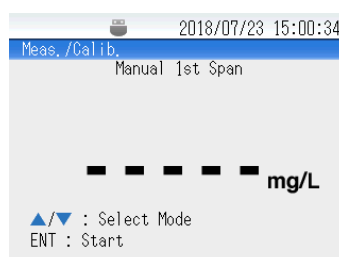

Fig. 43 Start of the manual span calibration (1st to 5th point) mode

5. Use the measuring cylinder or measuring syringe (for solvent) to dispense 8 mL of span liquid for calibration through the sample inlet.
6. Use the dropper to add one drop of hydrochloric acid through the sample port.
7. Use the measuring cylinder or measuring syringe (for sample) to dispense 16 mL of clean water through the sample inlet.
8. Press the ENT button.
The instantaneous value measurement screen appears.
The screen title shows [Manual 1st Span] and the process display shows the current status of the valves.
The operation guide display shows the stirring motor and valve operation buttons and [ENT: Calib. ESC: Return].

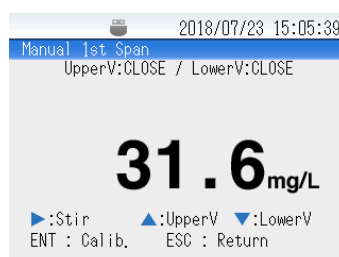

Fig. 44 Manual 1st span calibration - Instantaneous value measurement

9. If needed, execute purging (extraction, cell filling, and drainage) referring to "Screen operations in the manual measurement/calibration mode" (page 14).
10. Execute extraction and fill the cell at any time referring to steps 3. to 6. and "Screen operations in the manual measurement/calibration mode" (page 14).

11. Press the ENT button.

Measurement starts. The operation guide display shows [ESC: Cancel].

The elapsed time is shown (counting up). When measurement ends, the calibration result appears.

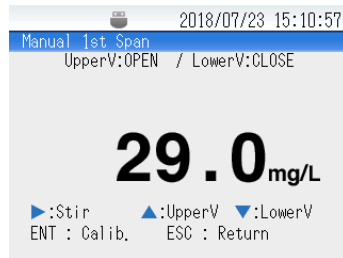

Fig. 45 Manual 1st span calibration- Measurement

When measurement ends normally, the measured value is held.

The operation guide display shows [ESC: Return].

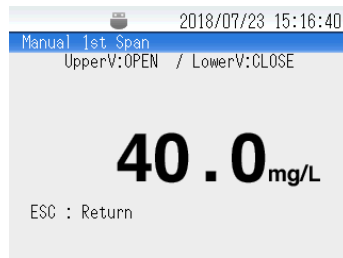

Fig. 46 Manual 1st span calibration - Result

12. Press the ESC button.

The instantaneous value measurement screen returns.

13. Execute drainage referring to "Screen operations in the manual measurement/ calibration mode" (page 14) at any time.

14. Press the ESC button.

The start state of the manual span calibration (1st to 5th point) mode returns.

15. As with manual 1st span, please also calibrate the manual 2nd span to the 5th span.

Tip

Unnecessary span points can be invalidated from the Calibration Setting .

The span point value is red color in the initial setting, but it changes to black color by performing calibration.

Span points return to red color by changing the span point value or turning it invalid after calibration, but it will turn to black color by turning it to original span point value again.

Note

RSD (coefficient of variation) is calculated from the result of 1st to 5th span calibration.





In the case of RSD <15% and RSD ≥ 15%, how to draw the calibration curve changes (For details, see original text of ASTM standard).

RSD can not be calculated if the span point is invalidated by three or more points.

In the case of RSD ≥ 15%, the concentration of the prepared span solution may be different from the set span point value.

Measurement

Measurement cautions

 CAUTION	
	<p>Chemical hazard (solvent S-316) Inhalation or accidental ingestion of a large amount of solvent S-316 may be harmful. Observe the following rules when handling:</p> <ul style="list-style-type: none"> • Ventilate the work area sufficiently. • Wear a protective mask and protective gloves. • Wash hands well after handling the solvent.
	<p>Chemical hazard (hydrochloric acid) Hydrochloric acid is toxic by skin or eye exposure. If it touches the skin, immediately rinse with water. If it reaches the eyes, rinse immediately under a large amount of running water and get medical attention.</p>
	<p>When dispensing liquids into the extraction tank, limit the solvent amount to 10 mL or less and the amount of the measurement liquid to 20 mL or less, so that the total volume of liquid does not exceed the upper limit line (30 mL). If the liquid exceeds the upper limit line, the liquid may leak and cause short-circuit in the internal wiring of the product. If liquid containing hydrochloric acid leaks and comes in contact with the skin, irritation and burning may occur.</p>
	<p>Discard the liquid collected in the beakers before overflow. If liquid containing hydrochloric acid overflows and comes in contact with the skin, irritation and burning may occur.</p>

To obtain correct measurement results, it is important to eliminate factors affecting measured values and to keep calibration and measurement conditions as uniform as possible. Observe the precautions below.

- If the temperature of the measurement liquid or solvent is lower than the inside of the main unit, condensation may form inside the main unit and the indicated value may be unsteady or shift.
If the room temperature is less than 5°C, the viscosity of solvent S-316 will increase and the indicated value may be low. In this case, raise the room temperature above 5°C, or set [Fill Cell Time] to a longer value.
- Avoid performing measurement at high temperature and high humidity. Moisture may cause the indicated value to shift.
- When the air has a high concentration of hydrocarbons, for instance in an oil refinery, hydrocarbons may be adsorbed inside the product and affect measurement. In this type of location, increase the [Number of Purge] value.
- Be sure to wash your hands before starting work. If oil from your fingers gets on the sample inlet on the product, the measuring utensils, or other parts, the measured value will be affected and correct measurement will be impossible.
- Perform measurement with the right cover closed. Measurement cannot be stable with the right cover open.
- Be sure to perform zero calibration before every measurement. Perform span calibration from once a day to once a week. When you change to a new solvent lot, perform zero calibration and span calibration before measurement using the calibration liquids prepared from the new lot of solvent.
- Be sure to perform zero calibration before performing span calibration. If zero calibration is performed after span calibration, correct measurement will be impossible.

- Purging is necessary to prevent effects from the previous measurement liquid. Set [Number of Purge] from 2 to 6. If the concentration changes by 100 mg/L or more from the previous measurement, set [Number of Purge] to 5 or more.
- When using the built-in extractor, maintain an extraction ratio of solvent:water = 1:2. The instructions in this manual indicate 8 mL of solvent and 16 mL of clean water or sample water to provide an extraction ratio of solvent:water = 1:2.
- When the built-in extractor is not used, the extraction ratio can be changed. However, be sure to keep the solvent to sample water extraction ratio the same between measurement and calibration. If the extraction ratios are not the same, measurement error will occur due to the differences in the water content of the solvent. In addition, this product is designed for measurement at an extraction ratio of solvent:sample water = 1:2. Other extraction ratios may cause greater measurement error and the specified product performance cannot be guaranteed.
- When measuring sample or reagent quantities, use suitable measuring utensils and measure accurately. When using a microsyringe or measuring syringe, take care that foam and bubbles are not drawn into the syringe. Foam and bubbles will increase measurement error.
- Dispense liquid slowly into the extraction tank. A vigorous dispense of liquid may cause overflow.
- When measurement is completed for the day, clean the flow paths inside the product (refer to "Rinsing the flow paths" (page 107)).
- If an abnormality occurs during measurement, calibration, or liquid drainage, operation may stop. The alarm icon will blink. Check the alarm information on the Current Alarm screen (refer to "Current Alarm screen" (page 71) and "Alarm displays and actions" (page 125)).

In addition, read "Operational precautions" and "Solvent handling precautions" in the front matter of this manual.

Preprocessing

■ Removing fine particles

If the sample water contains fine particles or other impurities, use an ashless cellulose quantitative filter paper (particle retention: 8 μm) to remove the impurities before dispensing the sample into the product.

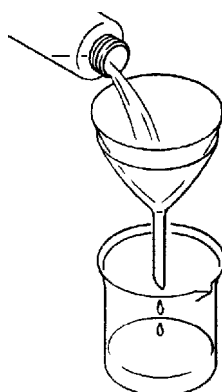

Fig. 47 Removal of fine particles

■ Performing preliminary extraction outside the product

For the following types of sample water, perform extraction outside the product prior to dispensing the sample into the product.

- Sample water that has an oil membrane or oil drops floating on the surface
It cannot be measured in a measuring utensil. Extraction must be performed using the entire sample.
- Sample water containing large amounts of suspended material (sand, organic materials, etc.)
It will clog the measuring utensil or internal filter, and may damage the measuring utensil or the product.
- Sample water that is difficult to separate from the solvent after extraction (sample water containing emulsifying substances)
If any incompletely separated solvent is sent to the water filter, emulsifying substances or water content in the solvent may cause clogging in the water filter and an accurate measurement will not be possible.

Reference

"Examples of measurement by extraction outside the product" (page 61)

Points to check prior to measurement

Did you perform calibration?	If not, first perform zero calibration, then perform span calibration.
Is the warm-up icon off?	If the warm-up icon is blinking, wait until it turns off.
Is the alarm icon off?	If the alarm icon is blinking, check the error information and remove the cause (refer to "List of alarms" (page 125)).
Are the beakers for drainage in place?	If not, set the beakers for drainage in place (refer to "Placing the beakers for drainage" (page 20)).

Items required

- OCMA-500 (this product)
- Measuring cylinders (20 mL) or syringes (20 mL, optional): 2 (for solvent and sample)
- Dropper (provided): 1 (for hydrochloric acid)
- Clean solvent S-316 (optional)
- Hydrochloric acid (refer to "Hydrochloric acid" (page 22))
- Sample water

Automatic measurement

■ Deciding the extraction time

40-second extraction results in a uniform extraction state for normal sample water, however, the optimum extraction time depends on the properties of the sample water.

If you do not know the optimum extraction time of the sample water to be measured, use semi-automatic measurement or manual measurement to vary the extraction time prior to automatic measurement, and compare with extraction outside the product to determine the optimum extraction time.

Reference

- "Examples of measurement by extraction outside the product" (page 61)
 - "Semi-automatic measurement" (page 54)
 - "Manual measurement" (page 58)
 - "Measurement condition settings" (page 23)
-

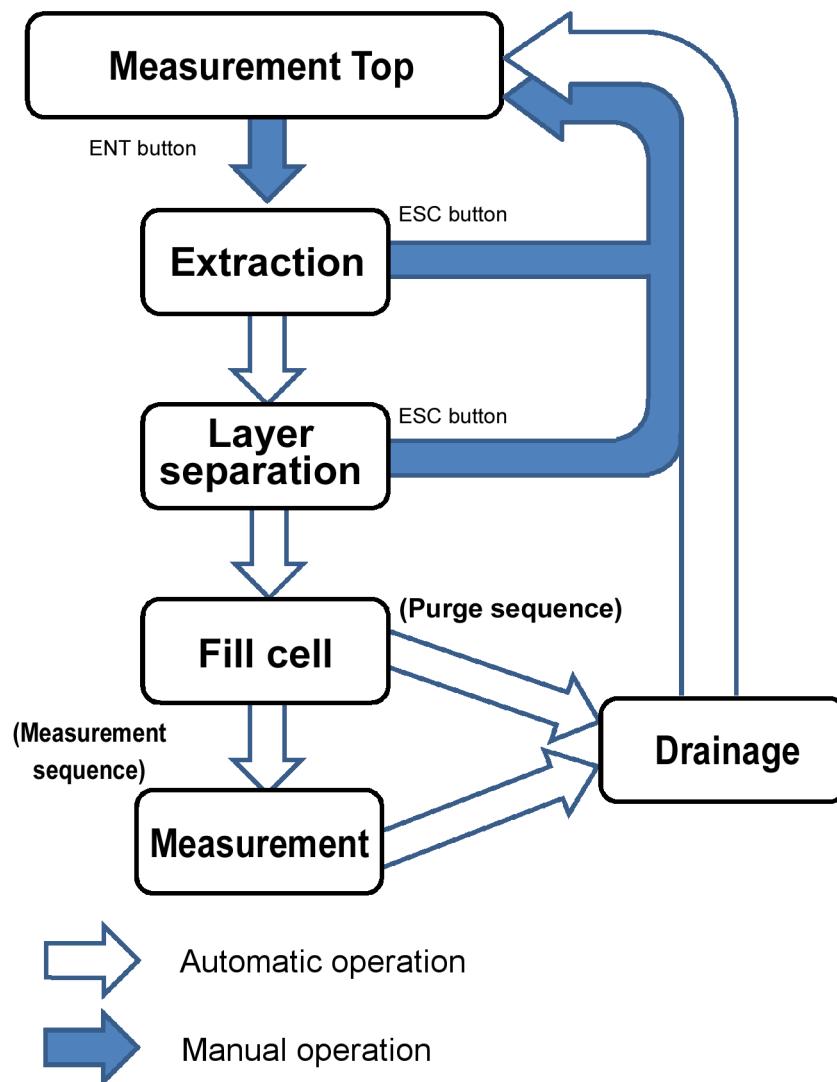
Flow scheme of operation**Fig. 48 Operation flow of automatic measurement**

Procedure

1. Set the measurement mode to "AUTO" on the Measurement Setting screen.
Change other settings as needed.

Reference

- "Measurement condition settings" (page 23)
- "Measurement Setting screen" (page 87)

2. Press the MEAS button or up/down button until the process display on the screen shows [Auto Measurement].

The automatic measurement mode is entered.

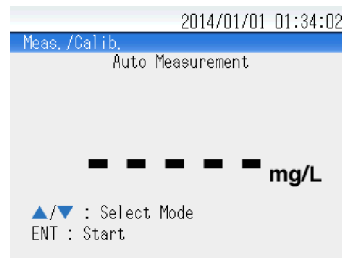

Fig. 49 Start of the automatic measurement mode

3. Use the measuring cylinder or measuring syringe (for solvent) to dispense 8 mL of clean solvent through the sample inlet.
4. Use the dropper to add one drop of hydrochloric acid through the sample port.
5. Use the measuring cylinder or measuring syringe (for sample) to dispense 16 mL of sample water through the sample inlet.
6. Press the ENT button.

If the set [Number of Purge] has not been completed:

The purge sequence starts. The screen title changes to [Auto Measurement (Purge: 1)] and the process display changes as follows as the sequence progresses:

[Extraction] → [Layer Separation] → [Fill Cell] → [Drainage]

The remaining time of the current process is shown (counting down).

When the purge sequence ends, the start state of the automatic measurement mode returns.

When the remaining [Number of Purge] is 0:

The measurement sequence starts. The screen title changes to [Auto Measurement: Measurement] and the process display changes as follows as the sequence progresses:

[Extraction] → [Layer Separation] → [Fill Cell] → [Measure]

The remaining time of the current process is shown (counting down) during extraction, layer separation, and cell filling. The elapsed time is shown (counting up) during measurement. When measurement ends, the measured value appears.

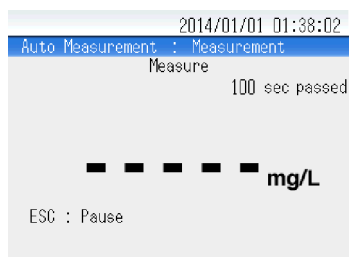

Fig. 50 Auto Measurement - Measurement

Note

- During layer separation, make sure that the solvent and sample water separate sufficiently. If the solvent and sample water are insufficiently separated, press the ESC button to cancel measurement, and lengthen [Separation Time] in the measurement settings. If the nature of the sample is such that layer separation is difficult, it is recommended that you use semi-automatic measurement or manual measurement in advance to determine the optimum [Separation Time].
- If the elapsed time exceeds 60 seconds and the measured value does not appear, replace the water filter (refer to "Replacing the water filter" (page 118)).

Tip

- If [Confirm Save] is set to "MANUAL", the operation guide display will show [ENT: Save ESC: Skip]. To save the measured value, press the ENT button. To skip, press the ESC button. For details on the [Confirm Save] setting, refer to "Confirm Save" (page 97).
- If [Save Memo] is set to "ON" in the measurement settings, a pop-up screen to input the data name will appear immediately before the measured value is saved. To save the measurement conditions or other memo with the measured value, enter the data name and press the ENT button. To save only the measured value and not an additional memo, press the ESC button. For details on the [Save Memo] setting, refer to "Save Memo" (page 97). For details on the pop-up screen to input the data name, refer to "Character keys" (page 18).

After the result appears, the measurement liquid is drained. During drainage, the process display on the screen shows [Drainage]. When drainage ends, the start state of the automatic measurement mode returns.

7. Repeat steps 3. to 6. until the set [Number of Purge] is completed and measurement starts.

Semi-automatic measurement

■ Flow scheme of operation

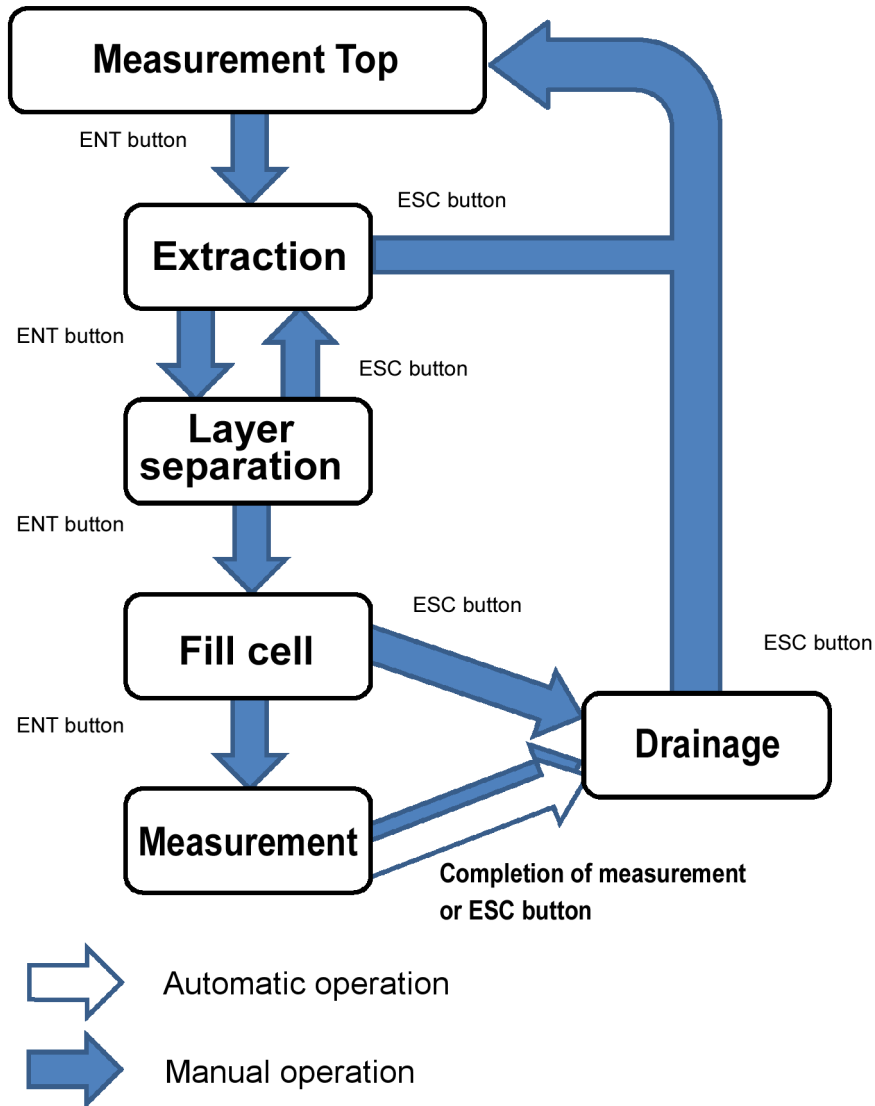

Fig. 51 Operation flow of semi-automatic measurement

Procedure

1. Set the measurement mode to "SEMI-AUTO" on the Measurement Setting screen. Change other settings as needed.

Reference

- "Measurement condition settings" (page 23)
- "Measurement Setting screen" (page 87)

2. Press the MEAS button or up/down button until the process display on the screen shows [Semi-Auto Measurement].

The semi-automatic measurement mode is entered.



Fig. 52 Start of the semi-automatic measurement mode

3. Use the measuring cylinder or measuring syringe (for solvent) to dispense 8 mL of clean solvent through the sample inlet.
4. Use the dropper to add one drop of hydrochloric acid through the sample inlet.
5. Use the measuring cylinder or measuring syringe (for sample) to dispense 16 mL of sample water through the sample inlet.
6. Press the ENT button.

Extraction starts. The screen title changes to [Semi-Auto Measurement] and the process display shows [Extraction].

The operation guide display shows [ENT: Next ESC: Previous].

The elapsed time appears (counting up).

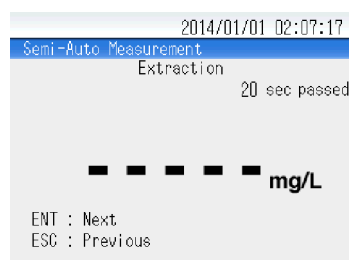

Fig. 53 Semi-automatic measurement - Extraction

7. Press the ENT button.

Layer separation starts. The process display on the screen shows [Layer Separation]. The elapsed time appears (counting up).

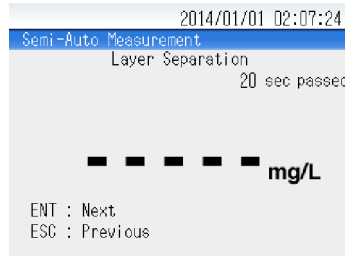

Fig. 54 Semi-automatic measurement - Layer separation

8. Make sure that the solvent and sample water have sufficiently separated, and press the ENT button.

Cell filling starts. The process display on the screen shows [Fill Cell]. The operation guide display shows [ENT: Next ESC: Drain]. The elapsed time appears (counting up).

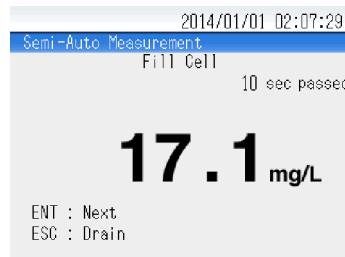

Fig. 55 Semi-automatic measurement - Fill Cell

9. Press the ENT button.

Measurement starts. The process display on the screen shows [Measure]. The operation guide display shows [ESC: Drain]. The elapsed time is shown (counting up). When measurement ends, the measured value appears.

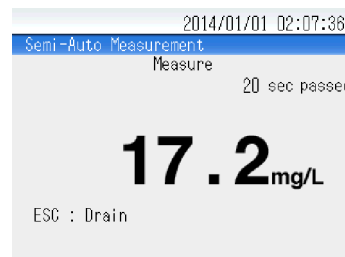

Fig. 56 Semi-automatic measurement - Measurement

Tip

- If [Confirm Save] is set to "MANUAL", the operation guide display will show [ENT: Save ESC: Skip]. To save the measured value, press the ENT button. To skip, press the ESC button. For details on the [Confirm Save] setting, refer to "Confirm Save" (page 97).
- If [Save Memo] is set to "ON" in the measurement settings, a pop-up screen to input the data name will appear immediately before the measured value is saved. To save the measurement conditions or other memo with the measured value, enter the data name and press the ENT button. To save only the measured value and not an additional memo, press the ESC button. For details on the [Save Memo] setting, refer to "Save Memo" (page 97). For details on the pop-up screen to input the data name, refer to "Character keys" (page 18).

After the result appears, the measurement liquid is drained. The process display on the screen shows [Drainage].

The operation guide display shows [ESC: Cancel]. The elapsed time appears (counting up).

10. Press the ESC button.

The start state of the semi-automatic measurement mode returns.

Tip

If the measured value is not saved in step 9., purging is executed.

After purging, you can return to step 3. to continue purging or execute measurement.

Manual measurement

■ Flow scheme of operation

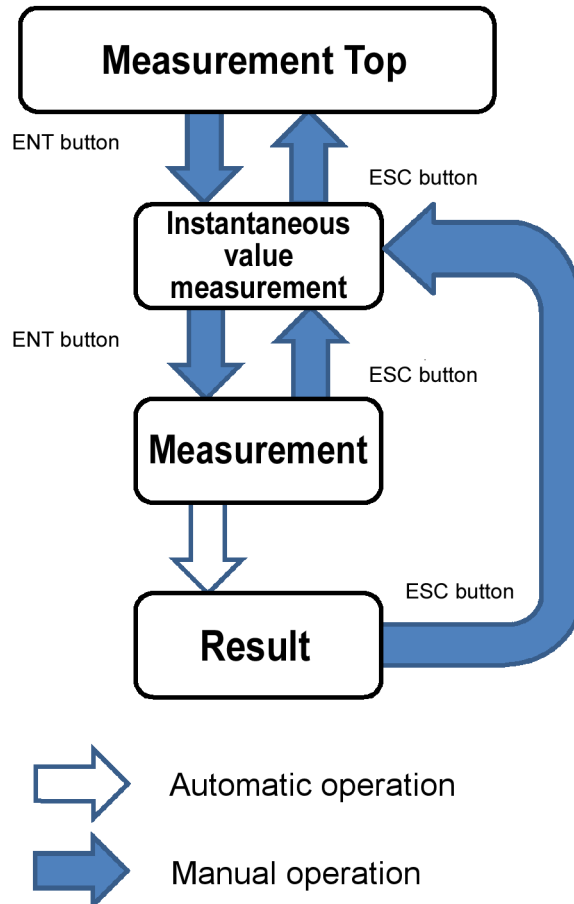

Fig. 57 Operation flow of manual measurement

Procedure

1. Set the measurement mode to "MANUAL" on the Measurement Setting screen.
Change other settings as needed.

Reference

- "Measurement condition settings" (page 23)
- "Measurement Setting screen" (page 87)

2. Press the MEAS button or up/down button until the process display on the screen shows [Manual Measurement].

The manual measurement mode is entered.

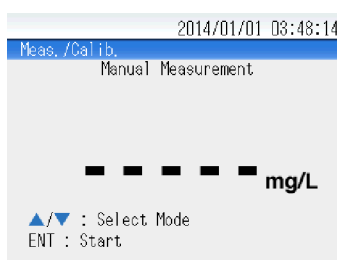

Fig. 58 Start of the manual measurement mode

3. Use the measuring cylinder or measuring syringe (for solvent) to dispense 8 mL of clean solvent through the sample inlet.
4. Use the dropper to add one drop of hydrochloric acid through the sample inlet.
5. Use the measuring cylinder or measuring syringe (for sample) to dispense 16 mL of sample water through the sample inlet.
6. Press the ENT button.

The instantaneous value measurement screen appears.

The screen title shows [Manual Measurement] and the process display shows the current status of the valves.

The operation guide display shows the stirring motor and valve operation buttons and [ENT: Save ESC: Skip].

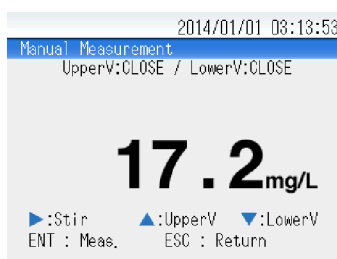

Fig. 59 Manual measurement - Instantaneous value measurement

7. If needed, execute purging referring to "Screen operations in the manual measurement/calibration mode" (page 14).
8. Execute extraction and fill the cell at any time referring to steps 3. to 6. and "Screen operations in the manual measurement/calibration mode" (page 14).

9. Press the ENT button.

Measurement starts.

The elapsed time is shown (counting up). When measurement ends, the measured value appears.

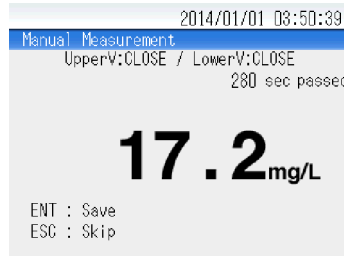

Fig. 60 Manual measurement - Measurement

Tip

- If [Confirm Save] is set to "MANUAL", the operation guide display will show [ENT: Save ESC: Skip]. To save the measured value, press the ENT button. To skip, press the ESC button. For details on the [Confirm Save] setting, refer to "Confirm Save" (page 97).
- If [Save Memo] is set to "ON" in the measurement settings, a pop-up screen to input the data name will appear immediately before the measured value is saved. To save the measurement conditions or other memo with the measured value, enter the data name and press the ENT button. To save only the measured value and not an additional memo, press the ESC button. For details on the [Save Memo] setting, refer to "Save Memo" (page 97). For details on the pop-up screen to input the data name, refer to "Character keys" (page 18).

If measurement ends normally, the measured value is held. The operation guide display shows [ESC: Return].

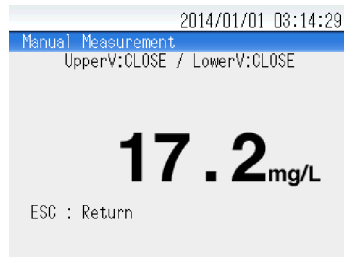

Fig. 61 Manual measurement - Result

10. Press the ESC button.

The instantaneous value measurement screen returns.

11. Execute drainage referring to "Screen operations in the manual measurement/calibration mode" (page 14) at any time.

12. Press the ESC button.

The start state of the manual measurement mode returns.

Examples of measurement by extraction outside the product

This section describes examples of extraction performed outside the product without using the built-in extractor.

The methods described below are only examples for reference. These methods may not be the optimum methods for some sample types. Use an extraction and measurement method that is appropriate for the actual sample.

■ Oil content in water

For the following types of sample water, extraction must be performed outside the product prior to dispensing the sample into the product.

- Sample water that has an oil membrane or oil drops floating on the surface
It cannot be measured in a measuring utensil. Extraction must be performed using the entire sample.
- Sample water containing large amounts of suspended material (sand, organic materials, etc.)
It will clog the measuring utensil or internal filter, and may damage the measuring utensil or the product.
- Sample water that is difficult to separate from the solvent after extraction (sample water containing emulsifying substances)
If any incompletely separated solvent is sent to the water filter, emulsifying substances or water content in the solvent may cause clogging in the water filter and an accurate measurement will not be possible.

Note

The water filter in the product serves to remove water particles. However if the sample water contains emulsifying substances, fine water particles may pass through the water filter. When this type of sample is measured repeatedly, the water filter tends to clog and accurate measurement is no longer possible.

If the measured value suddenly becomes a negative value or extremely low value, it is likely that water has entered the measurement cell due to water filter clogging or damage. (A negative value indicated during zero calibration is not abnormal.)

Replace the water filter at regular intervals, even if it does not appear to be dirty (refer to "Replacing the water filter" (page 118)).

● Checking layer separation

If a sample potentially contains emulsifying substances, check if the solvent layer and water layer are separated in advance.

Tip

The following are typical examples of water that is likely to contain emulsifying substances.

- Miscellaneous domestic gray water
 - Industrial wastewater
 - Activated sludge water (when the killed bacteria in the activated sludge is introduced, the content of the bacteria dissolves and acts in the same way as emulsifying substances.)
-

● Items required

- Glass container with a lid (screw-top bottle is recommended) (50 mL)
- Sample water
- Clean solvent S-316 (optional)

● **Checking procedure**

1. Dispense 8 mL of solvent and 16 mL of sample water into the glass container with a lid.
2. Screw the lid closed and shake for 1 minute by hand.

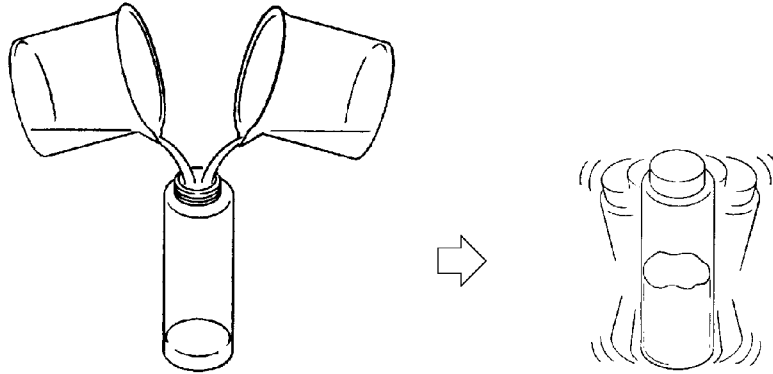

Fig. 62 Mixing solvent and sample water by shaking

3. Place on a flat surface, and check if the mixture completely separates into two layers after 20 seconds to 30 seconds.

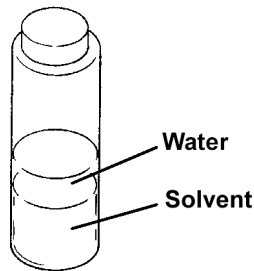

Fig. 63 Checking layer separation

If a boundary surface has formed between the solvent layer and water layer, it can be concluded that the layers "have been separated".

The following cases show that the layers have not been separated.

- Separation into two layers takes more than 40 seconds
- A whitish cloudy layer forms between the two layers
- Bubbles with a diameter of greater than 10 mm get formed in multiple places throughout the liquid and a boundary surface cannot be identified

● Extraction

● Items required

- Separating funnel (300 mL)^{*1}: 2 (for sample extraction and for zero point checking)
- Measuring cylinder (200 mL)^{*1}: 3 (for sample, for solvent, and for clean water)
- Dropper (provided): 1 (for hydrochloric acid)
- pH meter
- Filter paper (if suspended material will be removed and as needed)^{*2}
- Glass container (if suspended material will be removed or water will be removed from solvent layer)^{*1}
- Teflon membrane filter (mesh diameter 20 μm to 40 μm) (if water will be removed from solvent layer)
- Glass funnel^{*1} (if water will be removed from solvent layer)
- Measuring utensil (if water will be removed from solvent layer)
- Sample water
- Clean water^{*3}
- Hydrochloric acid (refer to "Hydrochloric acid" (page 22))
- Clean solvent S-316 (optional)
- Anhydrous sodium sulfate (Na₂SO₄) (if water will be removed from solvent layer)

Note

*1: Clean the glass utensils with solvent in advance and let air dry.

*2: Use solvent to elute and clean organic material from the filter paper in advance, and let air dry.

*3: Use the same clean water for the sequence of tasks from zero calibration to measurement.

- Normally pure water should be used.
 - If the sample contains large amounts of water-soluble substances, such as urea or NaCl, and the concentration is known, perform zero calibration using this oil-free aqueous solution.
-

● Extraction procedure

1. Measure 200 mL of clean water into the measuring cylinder for clean water, measure 100 mL of clean solvent into the measuring cylinder for solvent, and dispense these into the separating funnel for zero point checking.
2. Measure 160 mL to 200 mL of sample water into the measuring cylinder for sample, and dispense into the separating funnel for sample extraction.

Tip

If the sample contains emulsifying substances, it is recommended that you use a smaller amount of sample water (approx. 100 mL).

3. Measure an amount of clean solvent equal to 1/2 the amount of sample water in the measuring cylinder for solvent, and transfer this to the measuring cylinder for sample.
4. Rinse the inside of the measuring cylinder for sample with the solvent, and add this solvent to the separating funnel for sample extraction.
5. Use the dropper to add 0.2 mL to 0.5 mL (5 drops to 10 drops) of hydrochloric acid to each separating funnel (for sample extraction and for zero point checking).

Tip

If the sample contains emulsifying substances, there is no need to add hydrochloric acid.

6. Use the pH meter to check the pH value (pH 2 to pH 3) of each separating funnel (for sample extraction and for zero point checking).
7. Insert the stopper in each separating funnel (for sample extraction and for zero point checking) and shake for approx. 5 minutes.

Tip

If the sample contains emulsifying substances, it is recommended that you shake for a shorter time (approx. 1 minute).

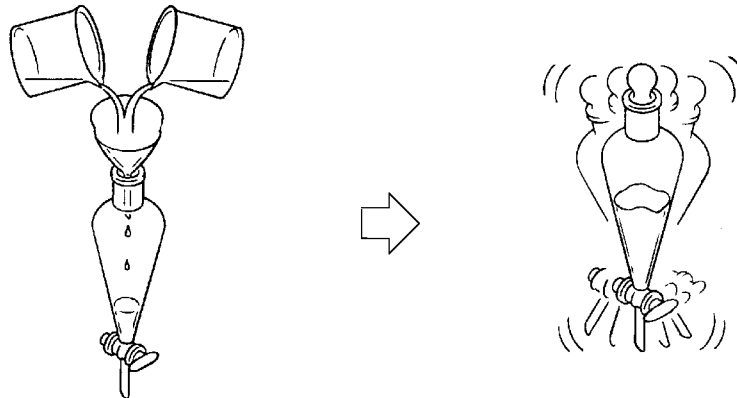

Fig. 64 Extraction

Note

The internal pressure will increase as you shake. Open the cock from time to time to reduce the internal pressure.

8. After shaking, wait until the water and solvent get separated, and check the status of the sample water. If almost no suspended material is visible and the water and solvent have separated, collect the solvent layer (lower layer) and use that as the measurement liquid. If there is suspended material or the water and solvent have not sufficiently separated and the solvent layer is cloudy, proceed to the "Removing suspended material" and "Removing water from the solvent layer" procedures.

● Removal of suspended material

1. Filter the solvent layer through the filter paper into the glass container and use this as the measurement liquid.

● Removing water from the solvent layer

1. Collect only parts that can be recognized as solvent in the glass container, and check the status of the liquid.

If no water particles are visible and the liquid is clear, use it as measurement liquid. If you can see water particles with a diameter of 0.1 mm or larger or the liquid appears whitish overall, follow the steps below to remove water from the solvent layer.

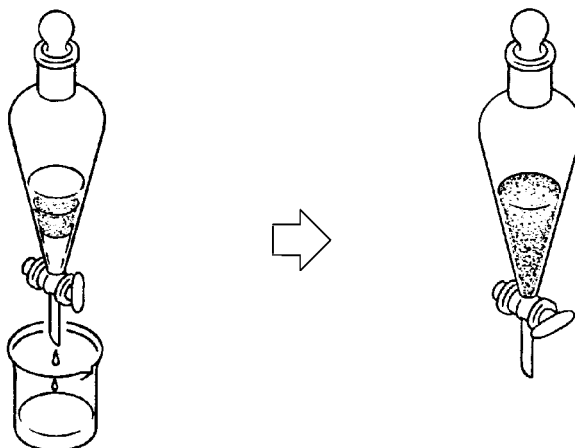

Fig. 65 Separating the solvent layer

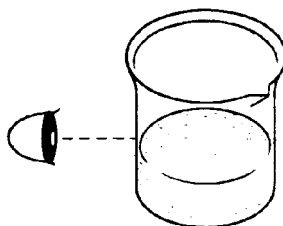

Fig. 66 Visually checking the solvent layer

2. Filter the liquid through the Teflon membrane filter.
3. Gradually add the anhydrous sodium sulfate and shake well to mix.

Tip

If the sample contains emulsifying substances, place filter paper in the funnel and filter the solvent layer into a container containing 10 g of anhydrous sodium sulfate.

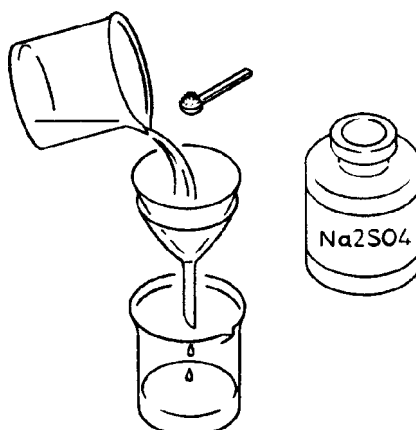

Fig. 67 Removing water from the solvent layer

4. Continue performing step 3. until the solvent layer is clear.
5. If anhydrous sodium sulfate crystals remain, filter with filter paper.
6. After waiting, collect the supernatant liquid using a measuring utensil and use this as measurement liquid.

● Zero calibration

Perform zero calibration using the conditions in the table below.

Parameter	Condition
Extraction Time	0 sec
Separation Time	0 sec
Number of Purge	3 or more
Zero liquid for calibration	Take 24 mL from the solvent layer in the separating funnel for zero point checking.

Reference

- "Calibration Setting screen" (page 99)
- "Calibration" (page 24)

● Span calibration

Perform span calibration using the conditions in the table below.

Parameter	Condition
Span Point	Concentration of span liquid
Extraction Time	0 sec
Separation Time	0 sec
Number of Purge	3 or more
Span liquid for calibration	Use 24 mL of span liquid for calibration.

Reference

- "Calibration Setting screen" (page 99)
- "Span liquid for calibration" (page 21)
- "Calibration" (page 24)

● Measurement

Perform measurement using the conditions in the table below.

Parameter	Condition
Extraction Time	0 sec
Separation Time	0 sec
Number of Purge	3 or more
Measurement liquid	Take 24 mL from the measurement liquid.

Reference

- "Measurement Setting screen" (page 87)
- "Measurement" (page 47)

Oil content in or on solids

Directly immerse the part in the solvent to extract the oil content.

Although an ultrasonic cleaner can be used for extraction. The solvent volatilization volume and changes in water content will be larger and may have a greater effect on the measured value. In addition, elution and peeling of the part may occur. Extraction by the immersion method is recommended.

To obtain a correct measurement result, it is important that the solvent conditions is the same for calibration and measurement. Observe the precautions below.

- Water is not used for extraction of oil content on metal parts.
Use the same lot of solvent for zero calibration and span calibration, which is used for extraction. Do not use water.
- Solvent volatilization during extraction will affect measurement results.
The effect of solvent volatilization can be reduced by performing, in parallel with extraction from the metal part, the same processing using solvent only, and using that solvent to perform zero calibration and span calibration. In particular, if an ultrasonic cleaner is used for extraction, always process the solvent to be used for zero calibration and span calibration with the ultrasonic cleaner as well.

Extraction

Items required

- Measuring cylinder (select a size appropriate for the amount of solvent)^{*1}
- Wide-mouthed glass container with lid (select a size appropriate for the size of the sample and the amount of solvent)^{*1}
- Ashless cellulose quantitative filter paper (particle retention: 8 μm)^{*2}
- Glass funnel^{*1}
- Glass container^{*1}
- Ultrasonic cleaner (if used)
- Part to be measured (referred to as sample in the rest of this section)
- Clean solvent S-316 (optional)

Note

*1: Clean the glass utensils with solvent in advance and let air dry.

*2: Use solvent to elute and to clean organic material from the filter paper in advance, and let air dry.

Extraction procedure

1. Place the sample in the wide-mouthed glass container with a lid.
2. Fill an amount of solvent into the measuring cylinder sufficient to immerse the entire sample.
3. Pour the measured solvent into the wide-mouthed container and immediately close the lid.
4. Wait with the lid closed, shaking from time to time, for 1 minute. If needed, the time can be extended. It is possible to apply the sonic cleaner with the lid closed (no more than 3 minutes).



Fig. 68 Oil content extraction from part (immersion)

Note

- Do not shake the container with the solvent and with closed lid hard. If it is shaken hard, the internal pressure will increase due to vaporization of the solvent and the solvent may spray out from gaps under the lid.
- After shaking, open the lid briefly to lower the internal pressure and then promptly close the lid.
- Do not apply the ultrasonic cleaner longer than 3 minutes.

5. Filter the liquid through the filter paper to remove foreign matter (particles, peeled fragments, etc.), and use it as the measurement liquid.

● **Zero calibration**

Perform zero calibration using the conditions in the table below.

Parameter	Condition
Extraction Time	0 sec
Separation Time	0 sec
Number of Purge	3 or more
Zero liquid for calibration	Use 24 mL of zero liquid for calibration.

Note

Do not introduce water during zero calibration.

Reference

- "Calibration Setting screen" (page 99)
- "Zero liquid for calibration" (page 21)
- "Calibration" (page 24)

● Span calibration

Perform span calibration using the conditions in the table below.

Parameter	Condition
Span Point	Concentration of span liquid
Extraction Time	0 sec
Separation Time	0 sec
Number of Purge	3 or more
Span liquid for calibration	Use 24 mL of span liquid for calibration.

Note

Do not introduce water during span calibration

Also set [Span Point] in the calibration settings to the same value as the net concentration of the span liquid, because water is not used.

Reference

- "Calibration Setting screen" (page 99)
- "Span liquid for calibration" (page 21)
- "Calibration" (page 24)

● Measurement

Perform measurement using the conditions in the table below.

Parameter	Condition
Extraction Time	0 sec
Separation Time	0 sec
Number of Purge	3 or more
Measurement liquid	Take 24 mL from the measurement liquid.

Reference

- "Measurement Setting screen" (page 87)
- "Measurement" (page 47)

Data Management

Data Top screen

The Data Top screen appears when the DATA button is pressed on the Measurement Top screen or Setting Top screen.

The Data Top screen shows a menu for data management.

Select an item with the up/down button and press the ENT button to move to the screen for the selected function.







Fig. 69 Data Top screen



Table 6 Menu on the Data Top screen

Item	Description	Page
Current Alarm	Opens the Current Alarm screen.	page 71
Measurement History	Opens the Measurement History screen.	page 72
Calibration History	Opens the Calibration History screen.	page 73
USB Memory	Opens the USB Memory screen.	page 74
Memory Clear	Opens the Memory Clear screen.	page 82

The buttons and button functions, which can be used with the Data Top screen appearing, are described in the table below.

Table 7 Button functions with the Data Top screen

Button	Function	Page
CAL button 	Switches between the zero calibration mode and span calibration mode.	page 24
MEAS button 	Opens the Measurement Top screen.	page 11
SET button 	Opens the Setting Top screen.	page 86
ENT button 	Enters the selected item.	-
Up button 	Selects the next item up.	-

Button		Function	Page
Down button		Selects the next item down.	-
ESC button		Returns to the Measurement Top screen.	page 10

Current Alarm screen

If [Current Alarm] is selected on the Data Top screen, the Current Alarm screen opens. The Current Alarm screen shows a list of the current alarms.







Fig. 70 Current Alarm screen

Note

For the alarms and their descriptions, refer to "Alarm displays and actions" (page 125).

The buttons and button functions, which can be used with the Current Alarm screen appearing, are described in the table below.

Table 8 Button functions with the Current Alarm screen

Button		Function	Page
Up button		Selects the next item up.	-
Down button		Selects the next item down.	-
Left button		Shows the previous page.	-
Right button		Shows the next page.	-
ESC button		Returns to the Data Top screen.	page 70

Measurement History screen

If [Measurement History] is selected on the Data Top screen, the Measurement History screen opens.





The Measurement History screen shows a list of the measurement history.

2013/08/05 10:00:09	
Measurement History	[1-4/36]
2013/08/05 09:57	
74.6 mg/L	
2013/08/05 09:44	abc
74.6 mg/L	
2013/08/05 09:15	123456789012345
37.2 mg/kg	(74.5 mg/L)
2013/08/05 08:56	1234567
36.2 mg/kg	(72.4 mg/L)

Fig. 71 Measurement History screen

The buttons and button functions, which can be used with the Measurement History screen appearing, are described in the table below.

Table 9 Button functions with the Measurement History screen

Button		Function	Page
Up button		Selects the next item up.	-
Down button		Selects the next item down.	-
Left button		Shows the previous page.	-
Right button		Shows the next page.	-
ESC button		Returns to the Data Top screen	page 70

Calibration History screen

If [Calibration History] is selected on the Data Top screen, the Calibration History screen opens.

The Calibration History screen shows a list of the calibration history.



2018/07/23 15:19:04	
Calibration History	[1-4/100]
2018/07/23 15:16	
1#40.0 mg/L	
2018/07/23 14:57	
1#40.0 mg/L	
2018/07/13 16:27	
200 mg/L	
2018/07/13 15:54	
0.0 mg/L	





Fig. 72 Calibration History screen

Tip

When "5point" is selected in Calib. Point screen, 0 #, 1 #, 2 #, 3 #, 4 #, 5 # are added in front of the span point value.

The buttons and button functions, which can be used with the Calibration History screen appearing, are described in the table below.

Table 10 Button functions with the Calibration History screen

Button		Function	Page
Up button		Selects the next item up.	-
Down button		Selects the next item down.	-
Left button		Shows the previous page.	-
Right button		Shows the next page.	-
ESC button		Returns to the Data Top screen	page 70

USB Memory screen

If [USB Memory] is selected on the Data Top screen, the USB Memory screen opens.

The USB Memory screen shows a menu for USB memory operations.

If an operation is selected with the up/down button and the ENT button is pressed, an execution confirmation message for the selected operation appears. To execute the selected operation, press the ENT button while the execution confirmation appears.

Note

- **Some USB memory stick may not work with the OCMA.**
Use a FAT/FAT32 formatted USB memory stick. Other formats may not be available with this product.
Even FAT/FAT32 formatted, some USB memory sticks may not work. In this case, try other type. If you need the USB memory stick manufactured and verified by HORIBA Advanced Techno, contact your local dealer.
- **To execute the operations with the USB Memory screen appearing, a USB memory stick must be connected to this product.**
- **If any of the operations are attempted without inserting a USB memory stick into the USB memory port, a message of "Process has failed" will appear.**
- **To connect a USB memory stick, refer to "Connecting a USB memory stick" (page 13).**







Fig. 73 USB Memory screen

Table 11 Menu on the USB Memory screen

Item	Description	Page
Save Measurement History	Shows an execution confirmation for [Save Measurement History].	page 76
Save Calibration History	Shows an execution confirmation for [Save Calibration History].	page 77
Save Settings	Shows an execution confirmation for [Save Settings].	page 79

The buttons and button functions, which can be used with the USB Memory screen appearing, are described in the table below.

Table 12 Button functions with the USB Memory screen

Button		Function	Page
ENT button		Shows an execution confirmation for the selected item.	-
Up button		Selects the next item up.	-
Down button		Selects the next item down.	-
ESC button		Returns to the Data Top screen	page 70

Execution confirmation for [Save Measurement History]

This is a confirmation message for saving the measurement history to a USB memory stick.

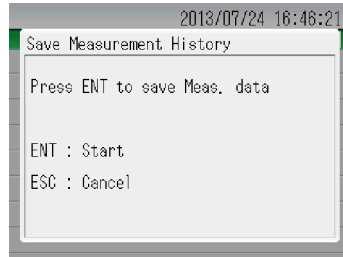

Fig. 74 Execution confirmation for [Save Measurement History]

The buttons and button functions, which can be used with the execution confirmation for [Save Measurement History] appearing, are described in the table below.

Table 13 Button functions with execution confirmation for [Save Measurement History]

Button		Function	Page
ENT button		Saves the measurement history to a USB memory stick.	-
ESC button		Closes the message.	-

If the ENT button is pressed, the measurement history is saved to a USB memory stick as a file in CSV format.

Each line describes one set of data. The values are separated by commas (",").

Saved items and formats are as shown in the table below.

Item (1st line is the title)	Format	Remarks
Date	yyyy/mm/dd hh:MM:ss	Date and time of measurement (year, month, day, hour, minute, second)
Value	dddd	Concentration after display conversion
Unit	uuuuu	Concentration units after display conversion (mg/L, mg/kg, mg/g, mg/PC)
Value (Raw)	dddd	Raw concentration value
Units (Raw)	uuuuu	Units of raw concentration value (fixed at mg/L)
Status	sssss	Error flag 0: No error 2: Warming up
Memo	mmmmmmmmmmmmmmmm	Entered memo

Output example:

Date,Value,Unit,Value(Raw),Unit(Raw),Status,Memo
 2001/01/01 12:34:56,123,mg/g,123,mg/L,0,sample01
 2001/01/02 12:34:56,123,mg/g,123,mg/L,2,sample02

■ Execution confirmation for [Save Calibration History]

This is a confirmation message for saving the calibration history to a USB memory stick.

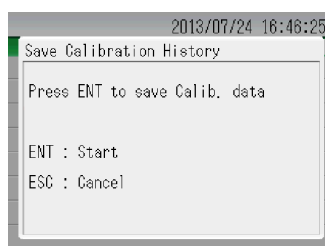



Fig. 75 Execution confirmation for [Save Calibration History]

The buttons and button functions, which can be used with the execution confirmation for [Save Calibration History] appearing, are described in the table below.

Table 14 Button functions with execution confirmation for [Save Calibration History]

Button		Function	Page
ENT button		Saves the calibration history to a USB memory stick.	-
ESC button		Closes the message.	-

If the ENT button is pressed, the calibration history is saved to a USB memory stick as a file in CSV format.

Each line describes one set of data. The values are separated by commas (",").

Saved items and formats are as shown in the table below.

Data Management

Item (1st line is the title)	Format	Remarks
Date	yyyy/mm/dd hh:MM:ss	Date and time of calibration (year, month, day, hour, minute, second)
# of Span Calib. Point	nnnnn	Calib. Point 1 : 1point 5 : 5point
Span Point	ppppp	Calib. Point 1: In case of 5 span calibration point, 1st span point Calib. Point 2: In case of 5 span calibration point, 2nd span point Calib. Point 3: In case of 5 span calibration point, 3rd span point Calib. Point 4: In case of 5 span calibration point, 4th span point Calib. Point 5: In case of 5 span calibration point, 5th span point
Standard	ddddd	Calibration concentration value (0 for zero calibration, set span value for span calibration)
Unit	uuuuu	Units of calibration concentration (fixed at mg/L)
Status	sssss	Error flag 0: No error 2: Warming up
SD	mmmmm	Standard deviation of calibration coefficient of span calibration points 1 to 5 (Display when complying with ASTM D7066-4)
RSD[%]	rrrrr	Coefficient of variation of calibration coefficient of span calibration points 1 to 5 (Display when complying with ASTM D7066-4)

Output example:

Date,# of Span Calib.point,Span point,Standard,Unit,Status,SD,RSD[%]

2001/01/01 12:34:56,0,0,mg/L,0

2001/01/02 12:34:56,200,mg/L,2

2001/01/02 12:34:56,5,5,200 mg/L,0,0.1,1.5

■ Execution confirmation for [Save Settings]

This is a confirmation message for saving the settings of the main unit to a USB memory stick.

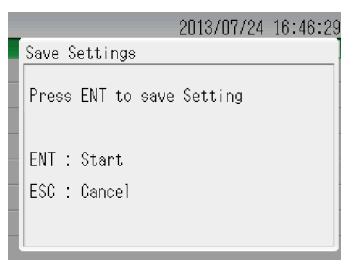



Fig. 76 Execution confirmation for [Save Settings]

The buttons and button functions, which can be used with the execution confirmation for [Save Settings] appearing, are described in the table below.

Table 15 Button functions with execution confirmation for [Save Settings]

Button		Function	Page
ENT button		Saves the settings of the main unit to a USB memory stick.	-
ESC button		Closes the message.	-

If the ENT button is pressed, the settings of the main unit are saved to a USB memory stick as a .cfg file.

The data ID and data value are indicated as text for each setting item category in the file. Saved items are shown in the table below.

Setting item category	Item (data ID)	Description	Page
MeasureSetting	ExtractTime	Extraction time	page 89
	LayerSeparationTime	Separation time	page 89
	FillSampleTime	Cell filling time	page 90
	MeasureLimitTime	Measurement limit time	page 90
	DrainTime	Drainage time	page 91
	PurgeNum	Numbers of purges	page 91
	StabWaitTime	Not used on this product.	-
	MeasMode	Measurement mode	page 92
	ConversionType	Measurement unit	page 92
	SolventVolume	Solvent volume	page 93
	SampleVolume	Sample volume	page 94
	Conc. Correction	Concentration correction	page 95
	ZeroShift	Zero shift value	page 96
	fl_ExtractLight	Use of extraction layer light source	page 96
	MeasTrig	Not used on this product.	-
	DataLog	Save confirmation setting	page 97
	fl_Memo	Memo Saving setting	page 97
	fl_Minus	Display setting for negative value	page 98
fl_RawData	Display setting for raw data	page 98	
CalibrationSetting	SpanValue	Set span value	page 100
	ExtractTime	Extraction time	page 100
	LayerSeparationTime	Separation time	page 101
	PurgeNum	Numbers of purges	page 101
	CalMode	Calibration mode	page 102
	Calib.Point	Span calibration point	page 102
	Calib.Curve	Calibration curve	page 102
SystemSetting	Language	Language setting	page 104

An example of a setting file is shown in Fig. 77.

```

=====
: OCMA-500
: Program No   : P2001239G
: Software Version : 1.17
=====
:
[MeasureSetting]
=====
: Measurement setting
=====
:ExtractTime      extract time      0, 10 - 600
:LayerSeparationTime  layer separation time  0, 10 - 600
:FillSampleTime    inflow time      30 - 3600
:MeasureLimitTime  measure limit time  60 - 3600
:DrainTime         drain time       30 - 3600
:PurgeNum          purge num        0 - 9
:StabWaitTime      stability wait time  0 - 300
:MeasMode          measure mode     0:Auto, 1:Semi-Auto, 2:Manual
:ConversionType    display unit     0:mg/L, 1:mg/kg, 2:mg/g, 3:mg/PC, 4:Abs.
:SolventVolume     solvent volume   1.0 - 20000.0
:SampleVolume      sample volume    0.001 - 10000.0
:Conc. Correction  concentration correction  0.1 - 9.9
:ZeroShift         zero shift coef. -100.0 - 100.0
:fl_ExtractLight   flag of extract light  0:OFF, 1:ON
:MeasTrig          measure start trigger  1:Manual
:DataLog           data logging type  0:Auto, 1:Manual
:fl_Memo           flag of save memo.    0:OFF, 1:ON
:fl_Minus          flag of display negative  0:OFF, 1:ON
:fl_RawData        flag of display raw value  0:OFF, 1:ON
=====
#ExtractTime : 40
#LayerSeparationTime : 30
#FillSampleTime : 60
#MeasureLimitTime : 300
#DrainTime : 30
#PurgeNum : 2
#StabWaitTime : 180
#MeasMode : 0
#ConversionType : 0
#SolventVolume : 8.000000E+00
#SampleVolume : 1.600000E+01
#Conc. Correction : 1.0
#ZeroShift : 0.000000E+00
#fl_ExtractLight : 1
#MeasTrig : 1
#DataLog : 0
#fl_Memo : 0
#fl_Minus : 1
#fl_RawData : 0
:
[CalibrationSetting]
=====
: Calibration setting
=====
:SpanValue        span calibration point  1 - 200

:SpanValue1       span calibration point  1 - 200
:SpanValue2       span calibration point  1 - 200
:SpanValue3       span calibration point  1 - 200
:SpanValue4       span calibration point  1 - 200
:SpanValue5       span calibration point  1 - 200
:ExtractTime      extract time      0, 10 - 600
:LayerSeparationTime  layer separation time  0, 10 - 600
:PurgeNum         purge num        0 - 9
:CalMode          calibration mode   0:Auto, 1:Manual
:Calib. Point     calibration point  0:1Point, 1:5Point
:Calib.Curve      calibration curve  RSD[%], --- :invalid
=====
#SpanValue : 2.000000E+02

#SpanValue1 : 4.000000E+01
#SpanValue2 : 8.000000E+01
#SpanValue3 : 1.200000E+02
#SpanValue4 : 1.600000E+02
#SpanValue5 : 2.000000E+02
#ExtractTime : 30
#LayerSeparationTime : 40
#PurgeNum : 0
#CalMode : 0
#Calib. Point : 1
#Calib.Curve : XX.X
:
[SystemSetting]
=====
: System setting
=====
:Language          Language setting      0:English, 1:Japanese, 2:Russian
:BackLightOffTime  Back Light OFF Time setting  0:OFF, 1:10min, 2:30min, 3:60min
=====
#Language : 1
#BackLightOffTime : 3

```

Fig. 77 Setting file example

Memory Clear screen

If [Memory Clear] is selected on the Data Top screen, the Memory Clear screen opens. The Memory Clear screen shows a menu for selection of data to be deleted from internal memory.

If an item is selected with the up/down button and the ENT button is pressed, an execution confirmation message for deletion of the selected data appears. To delete the selected data, press the ENT button while the execution confirmation appears.

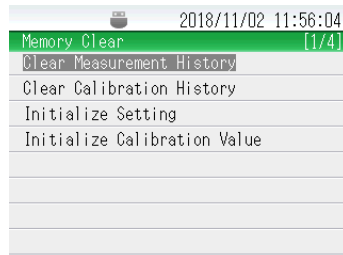





Fig. 78 Memory Clear screen

Table 16 Menu on the Memory Clear screen

Item	Description	Page
Clear Measurement History	Shows an execution confirmation for [Clear Measurement History].	page 83
Clear Calibration History	Shows an execution confirmation for [Clear Calibration History].	page 84
Initialize Setting	Shows an execution confirmation for [Initialize Setting].	page 84
Initialize Calibration value	Shows an execution confirmation for [Initialize Calibration Value].	page 85

The buttons and button functions, which can be used with the Memory Clear screen appearing, are described in the table below.

Table 17 Button functions with the Memory Clear screen

Button	Function	Page
ENT button 	Shows an execution confirmation for the selected item.	-
Up button 	Selects the next item up.	-
Down button 	Selects the next item down.	-
ESC button 	Returns to the Data Top screen.	page 70

■ Execution confirmation for [Clear Measurement History]

This is a confirmation message for clearing the measurement history.

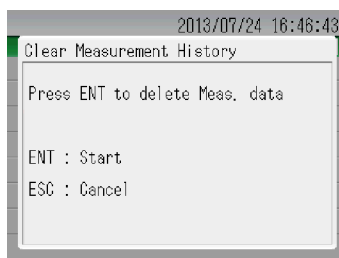



Fig. 79 Execution confirmation for [Clear Measurement History]

The buttons and button functions, which can be used with the execution confirmation for [Clear Measurement History] appearing, are described in the table below.

Table 18 Button functions with execution confirmation for [Clear Measurement History]

Button		Function	Page
ENT button		Clears the measurement history.	-
ESC button		Closes the message.	-

■ **Execution confirmation for [Clear Calibration History]**

This is a confirmation message for clearing the calibration history.

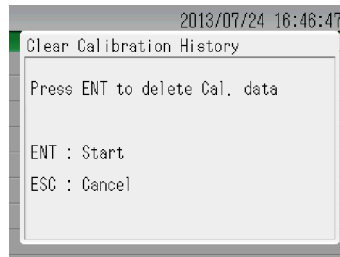

Fig. 80 Execution confirmation for [Clear Calibration History]

The buttons and button functions, which can be used with the execution confirmation for [Clear Calibration History] appearing, are described in the table below.

Table 19 Button functions with execution confirmation for [Clear Calibration History]

Button		Function	Page
ENT button		Clears the calibration history.	-
ESC button		Closes the message.	-

■ **Execution confirmation for [Initialize Setting]**

This is a confirmation message for initializing the settings.

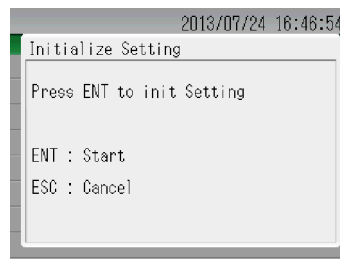

Fig. 81 Execution confirmation for [Initialize Setting]

The buttons and button functions, which can be used with the execution confirmation for [Initialize Setting] appearing, are described in the table below.

Table 20 Button functions with execution confirmation for [Initialize Setting]

Button		Function	Page
ENT button		Initializes the settings.	-
ESC button		Closes the message.	-

■ Execution confirmation for [Initialize Calibration Value]

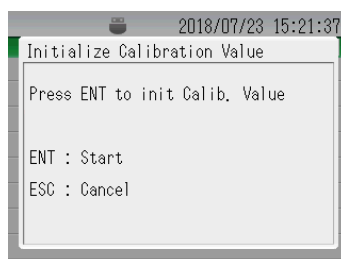



Fig. 82 Execution confirmation for [Initialize Calibration Value]

The buttons and button functions, which can be used with the execution confirmation for [Initialize Calibration Value] appearing, are described in the table below.

Table 21 Button functions with execution confirmation for [Initialize Calibration Value]

Button		Function	Page
ENT button		Initializes the settings.	-
ESC button		Closes the message.	-

Setting

Setting Top screen

The Setting Top screen appears when the SET button is pressed on the Measurement Top screen or the Data Top screen.

The Setting Top screen shows a menu for setting.

Select an item with the up/down button and press the ENT button to move to the screen for the selected function.

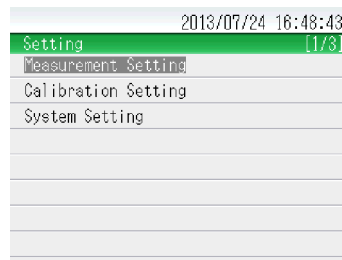







Fig. 83 Setting Top screen



Table 22 Menu on the Setting Top screen

Item	Description	Page
Measurement Setting	Opens the Measurement Setting screen.	page 87
Calibration Setting	Opens the Calibration Setting screen.	page 99
System Setting	Opens the System Setting screen.	page 103

The buttons and button functions, which can be used with the Setting Top screen appearing, are described in the table below.

Table 23 Button functions with the Setting Top screen

Button	Function	Page
DATA button 	Opens the Data Top screen.	page 70
CAL button 	Opens the Measurement Top screen.	page 11
MEAS button 	Opens the Measurement Top screen.	page 11
ENT button 	Enters the selected item.	-
Up button 	Selects the next item up.	-

Button		Function	Page
Down button		Selects the next item down.	-
ESC button		Returns to the Measurement Top screen.	page 11

Measurement Setting screen

If [Measurement Setting] is selected on the Setting Top screen, the Measurement Setting screen opens.

The Measurement Setting screen shows the current measurement settings.

If an item is selected with the up/down button and the ENT button is pressed, a pop-up screen appears to let you change the setting of the selected item.



2001/01/01 00:03:01	
Measurement Setting	[1/17]
Extraction Time	40sec
Separation Time	30sec
Fill Cell Time	60sec
Meas. Limit	300sec
Drainage Time	30sec
Number of Purge	2time
Meas. Mode	AUTO
Measurement Unit	mg/L

Fig. 84 Measurement Setting screen

The setting items on the Measurement Setting screen are shown in the table below.

Table 24 Items on the Measurement Setting screen





Item	Description	Setting range (unit) or selections	Page
Extraction Time	Sets the extraction time in the automatic measurement mode.	0 or 10 to 600 (sec)	page 89
Separation Time	Sets the layer separation time in the automatic measurement mode.	0 or 10 to 600 (sec)	page 89
Fill Cell Time	Sets the cell filling time in the automatic measurement and automatic calibration modes.	30 to 3600 (sec)	page 90
Meas. Limit	Sets the maximum measurement time in measurement and calibration. If the measured value does not stabilize, measurement ends when the set time (from the start of measurement or calibration) elapses and the measured value at that time is displayed.	60 to 3600 (sec)	page 90
Drainage Time	Sets the drainage time in the automatic measurement and automatic calibration modes.	30 to 3600 (sec)	page 91
Number of Purge	Sets the numbers of purges in the automatic measurement mode.	0 to 9 (time)	page 91
Meas. Mode	Sets the measurement mode.	AUTO, SEMI-AUTO, MANUAL	page 92
Measurement Unit	Sets the units of measured values.	mg/L, mg/kg, mg/g, mg/PC	page 92
Solvent Vol.	Sets the solvent volume used as a coefficient when the measured value is converted to mg/kg, mg/g, or mg/PC.	1.0 to 20000.0 (mL)	page 93

Setting

Item	Description	Setting range (unit) or selections	Page
Sample Vol.	Sets the sample volume used as a coefficient when the measured value is converted to mg/kg, mg/g, or mg/PC.	0.001 to 10000.0 or 1.0 to 10000.0 (The units depend on the set [Measurement Unit].)	page 94
Conc. Correction	Set the correction value for the measured value.	0.1 to 9.9	page 95
Zero Shift Value	Sets the shift correction value for zero liquid.	-100.0 to 100.0 (mg/L)	page 96
Use Light	Sets whether the LED that illuminates the inside of the extraction tank is ON or OFF.	OFF, ON	page 96
Confirm Save	Sets whether measurement data is automatically saved to internal memory after a measured value is settled, or a message appears for execution of the data save.	AUTO, MANUAL	page 97
Save Memo	Sets whether a memo indicating the measurement conditions or other information is saved together with the measured values, if measurement data is saved.	OFF, ON	page 97
Display Negative	Sets whether a negative value is displayed or zero is displayed, if the measured value is a negative value.	OFF, ON	page 98
Display Raw Data	Sets whether or not the concentration prior to conversion is displayed together with the converted value, if converted values are displayed.	OFF, ON	page 98

The buttons and button functions, which can be used with the Measurement Setting screen appearing, are described in the table below.

Table 25 Button functions with the Measurement Setting screen

Button	Function	Page
ENT button 	Shows the screen for setting the selected item.	-
Up button 	Selects the next item up.	-
Down button 	Selects the next item down.	-
ESC button 	Returns to the Setting Top screen.	page 86

■ Extraction Time

Use this screen to set the extraction time in the automatic measurement mode.



Fig. 85 Extraction Time screen

The following settings are available. The default setting is 40 (sec).

Setting range	Units
0 or 10 to 600	sec

For the buttons and functions, which can be used with this screen appearing, refer to Table 3 (page 17).

■ Separation Time

Use this screen to set the layer separation time in the automatic measurement mode.

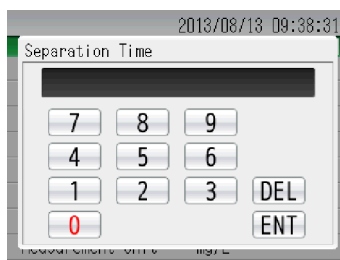

Fig. 86 Separation Time screen

The following settings are available. The default setting is 30 (sec).

Setting range	Units
0 or 10 to 600	sec

For the buttons and functions, which can be used with this screen appearing, refer to Table 3 (page 17).

■ Fill Cell Time

Use this screen to set the cell filling time in the automatic measurement and automatic calibration modes.



Fig. 87 Fill Cell Time screen

The following settings are available. The default setting is 60 (sec).

Setting range	Units
30 to 3600	sec

For the buttons and functions, which can be used with this screen appearing, refer to Table 3 (page 17).

■ Meas. Limit

Use this screen to set the maximum measurement time in measurement and calibration. If the measured value does not stabilize, measurement ends when the set time (from the start of measurement or calibration) elapses, and the measured value at that point is displayed.



Fig. 88 Meas. Limit screen

The following settings are available. The default setting is 300 (sec).

Setting range	Units
60 to 3600	sec

For the buttons and functions, which can be used with this screen appearing, refer to Table 3 (page 17).

■ Drainage Time

Use this screen to set the drainage time in the automatic measurement and automatic calibration modes.

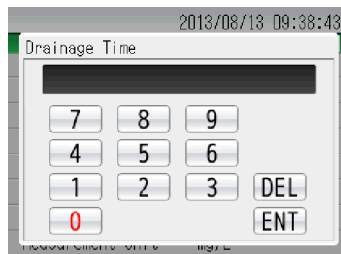

Fig. 89 Drainage Time screen

The following settings are available. The default setting is 30 (sec).

Setting range	Units
30 to 3600	sec

For the buttons and functions, which can be used with this screen appearing, refer to Table 3 (page 17).

■ Number of Purge

Use this screen to set the numbers of purges in the automatic measurement mode.

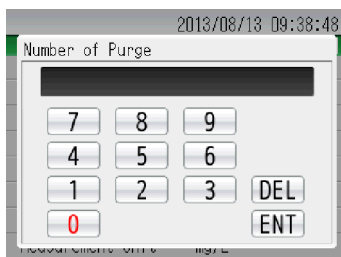

Fig. 90 Number of Purge screen

The following settings are available. The default setting is 2 (time).

Setting range	Units
0 to 9	time

For the buttons and functions, which can be used with this screen appearing, refer to Table 3 (page 17).

■ Meas. Mode

Use this screen to set the measurement mode.

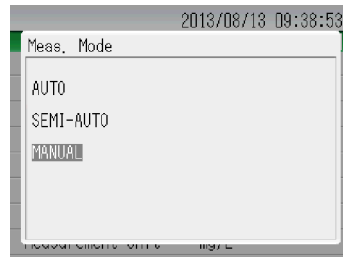

Fig. 91 Meas. Mode screen

The following settings are available. The default setting is "AUTO".

Selection	Description
AUTO	If the MEAS button is pressed, the automatic measurement mode is entered.
SEMI-AUTO	If the MEAS button is pressed, the semi-automatic measurement mode is entered.
MANUAL	If the MEAS button is pressed, the manual measurement mode is entered.

For the buttons and functions, which can be used with this screen appearing, refer to Table 2 (page 16).

■ Measurement Unit

Use this screen to set the units of measured values.

Reference

"Conversion of measurement units" (page 131)

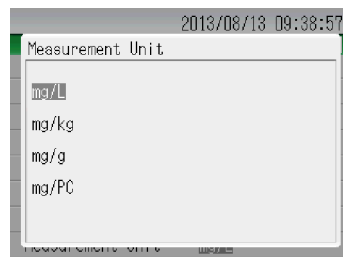

Fig. 92 Measurement Unit screen

The following settings are available. The default setting is "mg/L".

Selection	Description
mg/L	Shows measured concentration values in units of mg/L.
mg/kg	Shows measured concentration values in units of mg/kg.
mg/g	Shows measured concentration values in units of mg/g.
mg/PC	Shows measured concentration values in units of mg/PC.

For the buttons and functions, which can be used with this screen appearing, refer to Table 2 (page 16).

■ Solvent Vol.

Use this screen to enter the solvent volume to be used as a coefficient for conversion of the measurement unit into mg/kg, mg/g, or mg/PC.

Reference

"Conversion of measurement units" (page 131)



Fig. 93 Solvent Vol. screen

The following settings are available. The default setting is 8.0 (mL).

Setting range	Units
1.0 to 20000.0	mL

For the buttons and functions, which can be used with this screen appearing, refer to Table 3 (page 17).

Sample Vol.

Use this screen to enter the sample volume to be used as a coefficient for conversion of the measurement unit into mg/kg, mg/g, or mg/PC.

Reference

"Conversion of measurement units" (page 131)

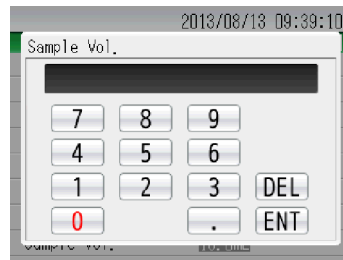

Fig. 94 Sample Vol. screen

The following settings are available. The default setting is 16.0 (the units depend on the set [Measurement Unit]).

Setting range	Units
0.001 to 10000.0	The units depend on the set [Measurement Unit] (refer to "Measurement Unit" (page 92)). kg if [Measurement Unit] is set to mg/kg g if [Measurement Unit] is set to mg/g
1.0 to 10000.0	PC if [Measurement Unit] is set to mg/PC

For the buttons and functions, which can be used with this screen appearing, refer to Table 3 (page 17).

■ Conc. Correction

Enter the coefficient for correcting the measured value.

Correction value = (measured value) × (Conc. correction input value)

Note

It can not be used when the number of span calibration points is 5point. ("Calibration (ASTM D7066-4)" (page 34))

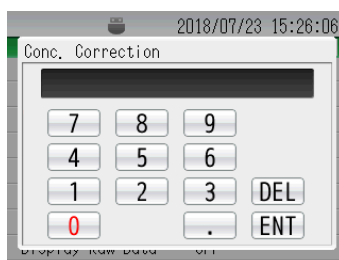

Fig. 95 Conc. Correction screen

The following settings are available. The default setting is 1.0.

Setting range	Description
0.1 to 9.9	Correct measured values.

■ Zero Shift Value

Use this screen to set the shift correction value for zero liquid.
The sum of this set value and the raw measured value is displayed as the measured value.

Reference

"Conversion of measurement units" (page 131)



Fig. 96 Zero Shift Value screen

The following settings are available. The default setting is 0.0 (mg/L).

Setting range	Units
-100.0 to 100.0	mg/L

For the buttons and functions, which can be used with this screen appearing, refer to Table 3 (page 17).

■ Use Light

Use this screen to set ON or OFF for the LED that illuminates the inside of the extraction tank. Turning ON the LED makes it easier to check liquid amounts and the boundary surface through the extraction tank window.

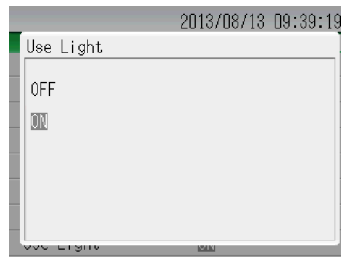

Fig. 97 Use Light screen

The following settings are available. The default setting is "ON".

Selection	Description
OFF	Turns OFF the LED that illuminates the inside of the extraction tank.
ON	Turns ON the LED that illuminates the inside of the extraction tank.

Tip

Even if [Use Light] is set to "ON", the LED will be turned OFF automatically when the period of the set [B-Light Off Time] has passed after the last button operation (refer to "B-Light Off Time" (page 104)). Any button operations turn ON the LED again.

For the buttons and functions, which can be used with this screen appearing, refer to Table 2 (page 16).

■ Confirm Save

Use this screen to set whether saving of settled measured values to internal memory takes place automatically or by manual selection.

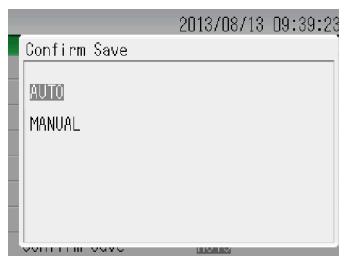

Fig. 98 Confirm Save screen

The following settings are available. The default setting is "AUTO".

Selection	Description
AUTO	Saving of settled measured values to internal memory takes place automatically.
MANUAL	After a measured value is settled, a message appears to let you select whether the values are saved to internal memory.

For the buttons and functions, which can be used with this screen appearing, refer to Table 2 (page 16).

■ Save Memo

Use this screen to set whether a memo indicating the measurement conditions or other information is saved together with the measured values, if measurement data is saved.



Fig. 99 Save Memo screen

The following settings are available. The default setting is "OFF".

Selection	Description
OFF	If measurement data is saved, only measured values are saved.
ON	If measurement data is saved, a memo indicating measurement conditions or other information is saved together with the measured values.

For the buttons and functions, which can be used with this screen appearing, refer to Table 2 (page 16).

■ Display Negative

Use this screen to set whether a negative value is displayed or zero is displayed when the measured value is a negative value.

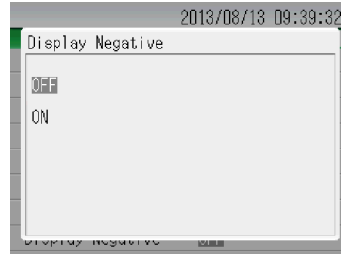

Fig. 100 Display Negative screen

The following settings are available. The default setting is "OFF".

Selection	Description
OFF	If the measured value is a negative value, zero is displayed.
ON	If the measured value is a negative value, the negative value is displayed.

For the buttons and functions, which can be used with this screen appearing, refer to Table 2 (page 16).

■ Display Raw Data

Use this screen to set whether the concentration prior to conversion is displayed, if converted values are displayed or not.



Fig. 101 Display Raw Data screen

The following settings are available. The default setting is "OFF".

Selection	Description
OFF	Raw data is not displayed, if converted values are displayed.
ON	Raw data is displayed, if converted values are displayed.

For the buttons and functions, which can be used with this screen appearing, refer to Table 2 (page 16).

Calibration Setting screen

If [Calibration Setting] is selected on the Setting Top screen, the Calibration Setting screen opens.

The Calibration Setting screen shows the current calibration settings.

If an item is selected with the up/down button and the ENT button is pressed, a pop-up screen appears to let you change the setting of the selected item.

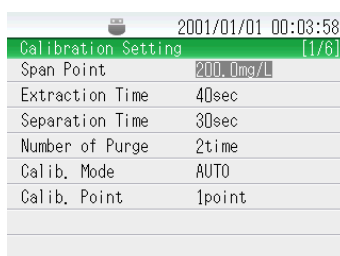

2001/01/01 00:03:58	
Calibration Setting [1/6]	
Span Point	200.0mg/L
Extraction Time	40sec
Separation Time	30sec
Number of Purge	2time
Calib. Mode	AUTO
Calib. Point	1point

Fig. 102 Calibration Setting screen





The setting items on the Calibration Setting screen are as shown in the table below.

Table 26 Items on the Calibration Setting screen

Item	Description	Setting range (units)	Page
Span Point	Sets the concentration of the span liquid for calibration.	1.0 to 200.0 (mg/L)	page 100
Extraction Time	Sets the extraction time in the automatic calibration mode.	0 or 10 to 600 (sec)	page 100
Separation Time	Sets the layer separation time in the automatic calibration mode.	0 or 10 to 600 (sec)	page 101
Number of Purge	Sets the numbers of purges in the automatic calibration mode.	0 to 9 (time)	page 101
Calib. Mode	Sets the calibration mode.	AUTO, MANUAL	page 102
Calib. Point	Sets the span calibration points.	1point, 5point	page 102
Calib. Curve	It is displayed when 5point is selected	-	page 102

The buttons and button functions, which can be used with the Calibration Setting screen appearing, are described in the table below.

Table 27 Button functions with the Calibration Setting screen

Button	Function	Page
ENT button 	Shows the screen for setting the selected item.	-
Up button 	Selects the next item up.	-
Down button 	Selects the next item down.	-
ESC button 	Returns to the Setting Top screen.	page 86

■ Span Point

Use this screen to set the concentration of the span liquid for calibration.

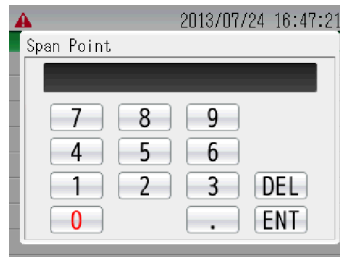

Fig. 103 Span Point screen

The following settings are available. The default setting is 200 (mg/L).

Setting range	Units
1.0 to 200.0	mg/L

For the buttons and functions, which can be used with this screen appearing, refer to Table 3 (page 17).

■ Extraction Time

Use this screen to set the extraction time in the automatic calibration mode.



Fig. 104 Extraction Time screen

The following settings are available. The default setting is 40 (sec).

Setting range	Units
0 or 10 to 600	sec

For the buttons and functions, which can be used with this screen appearing, refer to Table 3 (page 17).

■ Separation Time

Use this screen to set the layer separation time in the automatic calibration mode.

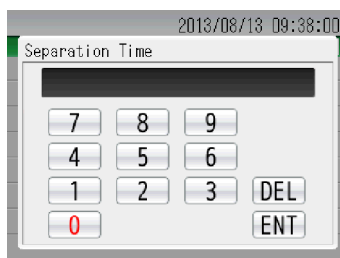

Fig. 105 Separation Time screen

The following settings are available. The default setting is 30 (sec).

Setting range	Units
0 or 10 to 600	sec

For the buttons and functions, which can be used with this screen appearing, refer to Table 3 (page 17).

■ Number of Purge

Use this screen to set the numbers of purges in the automatic calibration mode.

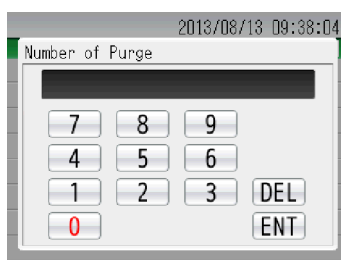

Fig. 106 Number of Purge screen

The following settings are available. The default setting is 2 (time).

Setting range	Units
0 to 9	time

For the buttons and functions, which can be used with this screen appearing, refer to Table 3 (page 17).

■ **Calib. Mode**

Use this screen to set the calibration mode.

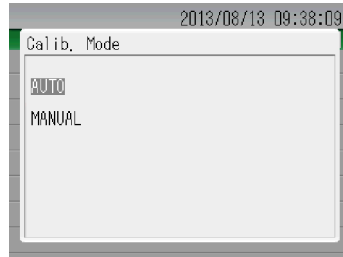

Fig. 107 Calib. Mode screen

The following settings are available. The default setting is "AUTO".

Selection	Description
AUTO	If the CAL button is pressed, the automatic calibration mode is entered.
MANUAL	If the CAL button is pressed, the manual calibration mode is entered.

For the buttons and functions, which can be used with this screen appearing, refer to Table 2 (page 16).

■ **Calib. Point**

Use this screen to set the span calibration points.

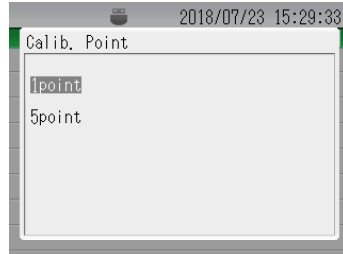

Fig. 108 Calib. Point screen

The following settings are available. The default setting is "1point".

Selection	Description
1point	Perform span calibration with 1point.
5point	It's used when complying with ASTM D7066-4 (page 34). Perform span calibration with 5point.

For the buttons and functions, which can be used with this screen appearing, refer to Table 2 (page 16).

■ **Calib. Curve**

It is displayed when 5point is selected (Complying with ASTM D7066-4).

Reference

「Calibration (ASTM D7066-4)」 (page 34)

System Setting screen

If [System Setting] is selected on the Setting Top screen, the System Setting screen opens.

The System Setting screen shows the current system settings.

If an item is selected with the up/down button and the ENT button is pressed, a pop-up screen appears to let you change the setting of the selected item.

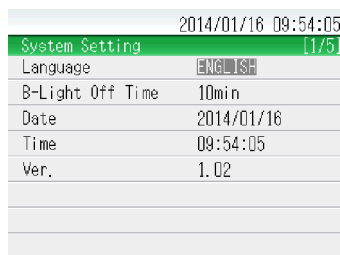

Fig. 109 System Setting screen





The setting items on the System Setting screen are as shown in the table below.

Table 28 Items on the System Setting screen

Item	Description	Setting range or selections	Page
Language	Sets the language.	English, Japanese, Russian, Korean, Chinese, French German	page 104
B-Light Off Time	Sets the time of turning OFF the light of the LCD and extraction tank automatically.	OFF, 10 min, 30 min, 60 min	page 104
Date	Sets the date.	2000/01/01 to 2099/12/31	page 105
Time	Sets the current time.	00:00 to 23:59	page 105
Ver.	Shows the software version (fixed value) in the right column.	-	-

The buttons and button functions, which can be used with the System Setting screen appearing, are described in the table below.

Table 29 Button functions with the System Setting screen

Button	Function	Page
ENT button 	Shows the screen for setting the selected item.	-
Up button 	Selects the next item up.	-
Down button 	Selects the next item down.	-
ESC button 	Returns to the Setting Top screen	page 86

Note

The screen does not change, if [Ver.] is selected and the ENT button is pressed.

■ Language

Use this screen to set the system language.



Fig. 110 Language screen

The following settings are available. The default setting is "ENGLISH".

Selection	Description
English	Displays in English.
Japanese	Displays in Japanese.
Russian	Displays in Russian.
Korean	Displays in Korean.
Chinese	Displays in Chinese.
French	Displays in French.
German	Displays in German.

For the buttons and functions, which can be used with this screen appearing, refer to Table 2 (page 16).

■ B-Light Off Time

Use this screen to set the time of turning OFF the light of the LCD and extraction tank automatically.



Fig. 111 B-Light Off Time screen

The following settings are available. The default setting is "10 min".

Selection	Description
OFF	The light of the LCD and extraction tank is not turned OFF automatically.
10 min	The light of the LCD and extraction tank is turned OFF 10 minutes after the last button operation.
30 min	The light of the LCD and extraction tank is turned OFF 30 minutes after the last button operation.
60 min	The light of the LCD and extraction tank is turned OFF 60 minutes after the last button operation.

For the buttons and functions, which can be used with this screen appearing, refer to Table 2 (page 16).

■ Date

Use this screen to set the date.

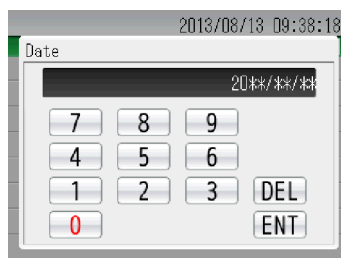

Fig. 112 Date screen

The following settings are available.

Setting range
2000/01/01 to 2099/12/31

For the buttons and functions, which can be used with this screen appearing, refer to Table 3 (page 17).

■ Time

Use this screen to set the current time.

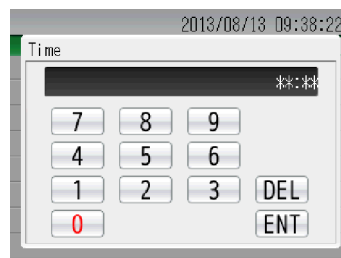

Fig. 113 Time screen

The following settings are available.

Setting range
00:00 to 23:59

For the buttons and functions, which can be used with this screen appearing, refer to Table 3 (page 17).

Maintenance

Contact for maintenance

Manufacturer: HORIBA Advanced Techno Co., Ltd.
31, Miyanonishi-cho, Kisshoin Minami-ku, Kyoto 601-8306, Japan

Maintenance item list

To keep this product in good condition and operating at top performance, perform maintenance regularly.

Table 30 Maintenance items

Item	Maintenance interval/frequency	Page
Rinsing the flow paths	When measurement is completed for the day	page 107
Inspecting the absorbent sheet	Once a week	page 108
Cleaning the fan filter	Once a week	page 109
Washing the fan filter	Once a month	page 110
Washing the extraction tank	Once a year or if it becomes difficult to see the oil-water boundary surface through the extraction tank window	page 111
Removing liquid from the air hole of the extractor	If liquid gets into the extractor air hole	page 116
Replacing the water filter	If it takes longer than 60 seconds from the start of measurement until settlement of a measured value	page 118
Drying the measurement cell	If the measurement cell gets wet	page 121

Before maintenance, drain the liquid from the extraction tank (refer to "Drainage mode operation" (page 12)).

Rinsing the flow paths



CAUTION



Chemical hazard (solvent S-316)

Inhalation or accidental ingestion of a large amount of solvent S-316 may be harmful.

Observe the following rules when handling:

- Ventilate the work area sufficiently.
- Wear a protective mask and protective gloves.
- Wash hands well after handling the solvent.

By keeping the flow paths inside the product clean, product failures can be prevented. When measurement is completed for the day, rinse the flow paths inside the product with clean solvent S-316 and pure water.

■ Maintenance interval guideline

When measurement is completed for the day

■ Items required

- Measuring cylinders (20 mL) or syringes (20 mL, optional): 2 (for solvent and sample)
- Clean solvent S-316 (optional)
- Pure water



■ Rinsing procedure

1. Check the measurement condition settings and set the measurement mode to "MANUAL".

Reference

- "Measurement condition settings" (page 23)
 - "Measurement Setting screen" (page 87)
2. Press the MEAS button or up/down button until the process display on the screen shows [Manual Measurement].
The manual measurement mode is entered.
 3. Use the measuring cylinder or measuring syringe (for solvent) to dispense 8 mL of clean solvent through the sample inlet.
 4. Use the measuring cylinder or measuring syringe (for sample) to dispense 16 mL of pure water through the sample inlet.
 5. Press the ENT button.
The instantaneous value measurement screen appears.
 6. Close the drainage valve and open the fill cell valve referring to "Screen operations in the manual measurement/calibration mode" (page 14).
Cell filling starts.
 7. After approx. 60 seconds, open the fill cell valve and drainage valve referring to "Screen operations in the manual measurement/calibration mode" (page 14).
Liquid drainage starts.
 8. After liquid drainage is finished, press the ESC button.
The start state of the manual measurement mode returns.
 9. Repeat steps 3. to 8. at least 3 times.

Inspecting the absorbent sheet

 CAUTION	
	<p>Chemical hazard (solvent S-316) Inhalation or accidental ingestion of a large amount of solvent S-316 may be harmful. Observe the following rules when handling:</p> <ul style="list-style-type: none"> • Ventilate the work area sufficiently. • Wear a protective mask and protective gloves. • Wash hands well after handling the solvent.
	<p>Take care not to pinch your fingers when opening or closing the right cover. During closing the right cover, do not release your hand until you hear a click sound.</p>

If the absorbent sheet on the tray in the main unit is wet, the liquid collected into the tray may overflow.

Inspect the absorbent sheet status on a regular basis and dry it, if necessary.

■ Maintenance interval guideline

Once a week

■ Items required

- Protection gloves
- Tweezers
- Absorbent sheet (accessory or optional): 1 (as needed)

■ Work procedure

1. Turn OFF the power.
2. Open the right cover.
3. Check the status of the absorbent sheet placed on the tray under the extraction tank.

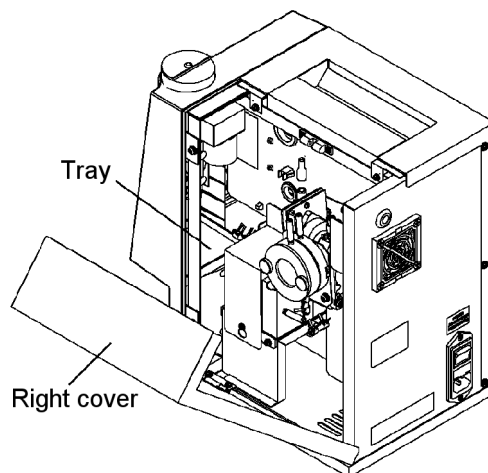

Fig. 114 Tray

4. If the absorbent sheet is wet, take out the sheet and dry it by squeezing or putting it in a well-ventilated space. Then, put it back on the tray.
 If the absorbent sheet is deteriorated, replace it with new one.
5. Close the right cover.

Cleaning the fan filter

If the filter, attached to the fan vent, starts to clog and the internal temperature rises, accurate measurement values can no longer be obtained and there is a risk of product failure. Clean the fan filter on a regular basis.

■ Maintenance interval guideline

Once a week

■ Items required

- Flathead screwdriver or similar tool

■ Work procedure

1. Turn OFF the power.
2. Use the flathead screwdriver to remove the retainer from the fan vent on the back of the main unit.

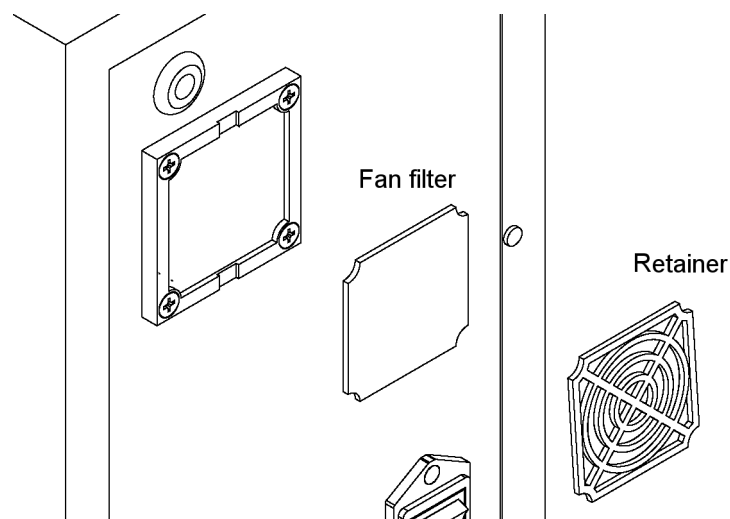

Fig. 115 Removing the fan filter

3. Remove the fan filter and tap to clean.

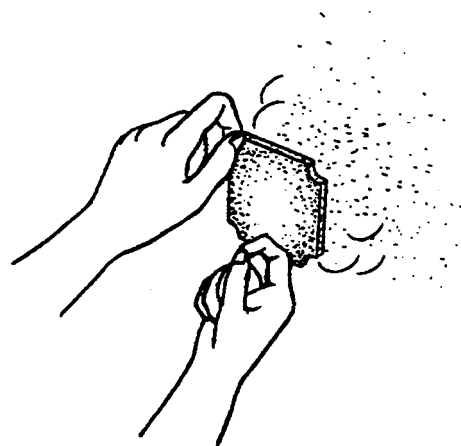

Fig. 116 Cleaning the fan filter

4. Re-attach the fan filter and retainer.

Washing the fan filter

If the filter, attached to the fan vent, starts to clog and the internal temperature rises, accurate measurement values can no longer be obtained and there is a risk of product failure. Wash the fan filter on a regular basis.

■ Maintenance interval guideline

Once a month

■ Items required

- Flathead screwdriver or similar tool

■ Work procedure

1. Turn OFF the power.
2. Use the flathead screwdriver to remove the retainer from the fan vent on the back of the main unit.

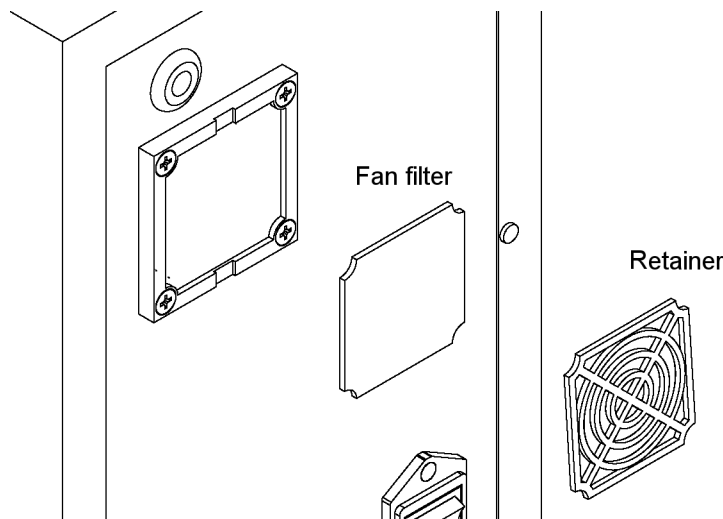

Fig. 117 Removing the fan filter

3. Remove the fan filter and wash with water to remove dirt.
4. Allow the fan filter to dry completely.
5. Re-attach the fan filter and retainer.

Washing the extraction tank



CAUTION

**Chemical hazard (solvent S-316)**

Inhalation or accidental ingestion of a large amount of solvent S-316 may be harmful.

Observe the following rules when handling:

- Ventilate the work area sufficiently.
- Wear a protective mask and protective gloves.
- Wash hands well after handling the solvent.



Take care not to pinch your fingers when opening or closing the right cover.

During closing the right cover, do not release your hand until you hear a click sound.

If the extraction tank gets dirty, it becomes difficult to see the oil-water boundary surface through the extraction tank window. Wash the extraction tank on a regular basis.

■ Maintenance interval guideline

Once a year or if it becomes difficult to see the oil-water boundary surface through the extraction tank window

■ Items required

- Tissue paper
- Pure water or clean solvent S-316 (optional)

Note

Use pure water or clean solvent S-316 to wash the extraction tank.

■ Work procedure

Note

Observe the precautions below when working.

- If assembling the extractor after washing, make sure the packing is not twisted and the fixing screw is not loose. If the packing is twisted or the fixing screw is loose, liquid will leak from that part.
-

1. Turn OFF the power.
2. Remove the sample inlet and open the right cover.

3. Pull out the latch knobs (2 places).

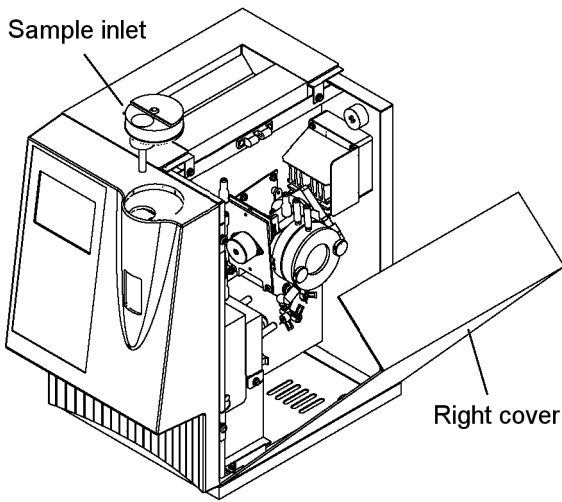

Fig. 118 Removing the sample inlet

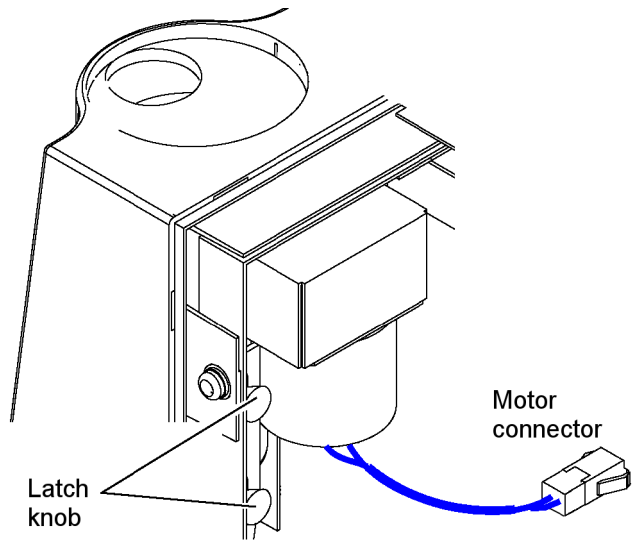

Fig. 119 Latch knobs

4. Disconnect the extractor joint and motor connector, and remove the extractor.

5. Loosen the fixing screw and remove the extraction tank.

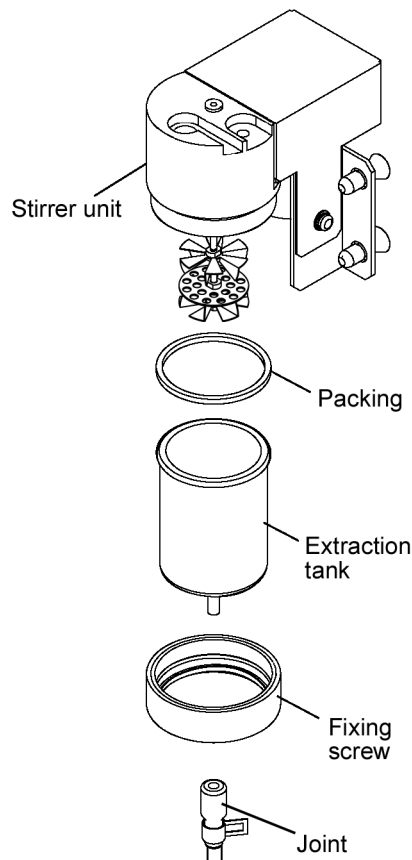

Fig. 120 Extractor

6. Use pure water or clean solvent S-316 to wash the extraction tank.

7. Remove droplet inside the extraction tank with tissue paper.

8. Assemble the extractor.

Reverse the stirrer unit, and put the packing on the plane surface inside the threaded portion so as not to protrude from the stirrer unit.

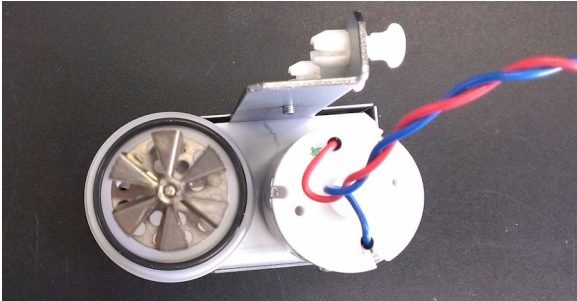

Fig. 121 Correct packing position

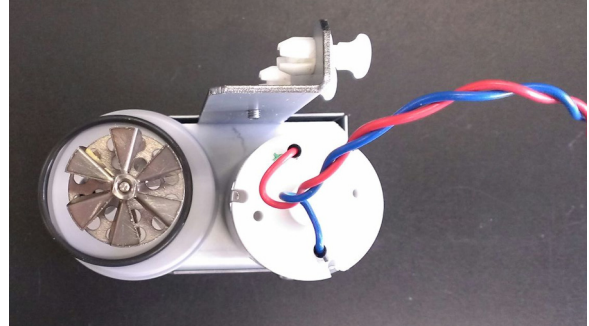

Fig. 122 Incorrect packing position

9. Put the extraction tank on the packing.

Put the extraction tank so that the upper limit line comes to the left side with the stirring motor on the right side.

Upper limit line



Stirring motor

Fig. 123 Extraction tank on the packing

10. Tighten a fixing screw slowly.
If you feel resistance of the packing, tighten the fixing screw 45 degree or until the end.
Excessive tightening may twist the packing, resulting leakage.

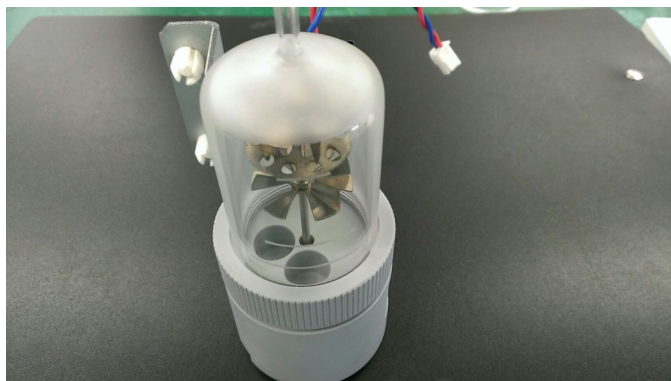

Fig. 124 Extraction tank on the packing

11. Make sure that there is no backlash between the stirrer unit and the extraction tank. Observe the inside of the extraction tank and make sure that the packing does not run off the inside. When the packing runs off the inside, perform this work from the step 7.



Fig. 125 Packing runs off the inside of the extraction tank

12. Connect the joint to the extractor and replace the extractor in its original position.
13. Connect the motor connector.
14. Close the right cover and attach the sample inlet.
15. Turn ON the power.
16. Set the measurement mode to "MANUAL" on the Measurement Setting screen.

Reference

- "Measurement condition settings" (page 23)
 - "Measurement Setting screen" (page 87)
-

17. Press the MEAS button or up/down button until the process display on the screen shows [Manual Measurement].
18. Use a measuring cylinder or measuring syringe (for solvent) to dispense 20 mL to 30 mL of clean solvent through the sample inlet.

19. Press the ENT button.

The instantaneous value measurement screen appears.

20. Close the drainage valve and open the fill cell valve referring to "Screen operations in the manual measurement/calibration mode" (page 14).

Cell filling starts.

21. Make sure that there is no liquid leakage from the extraction tank. If liquid is leaking, reassemble the extractor.**22. Open the fill cell valve and drainage valve referring to "Screen operations in the manual measurement/calibration mode" (page 14).**



Liquid drainage starts.

23. After liquid drainage is finished, press the ESC button.

The start state of the manual measurement mode returns.

24. Close the right cover.

Removing liquid from the air hole of the extractor

 CAUTION	
	<p>Chemical hazard (solvent S-316) Inhalation or accidental ingestion of a large amount of solvent S-316 may be harmful. Observe the following rules when handling:</p> <ul style="list-style-type: none"> • Ventilate the work area sufficiently. • Wear a protective mask and protective gloves. • Wash hands well after handling the solvent.
	<p>Take care not to pinch your fingers when opening or closing the right cover. During closing the right cover, do not release your hand until you hear a click sound.</p>

If too much water is poured into the extraction tank and the water overflows, liquid may enter the air hole at the top of the extractor.

If this happens, promptly remove the liquid from the air hole.

If extraction is performed with liquid in the air hole, liquid may spray from the sample inlet.

■ Maintenance interval guideline

If liquid gets into the extractor air hole

■ Items required

- Syringe

■ Work procedure

1. Turn OFF the power.
2. Remove the sample inlet.
3. Open the right cover.
4. Pull out the latch knobs (2 places).

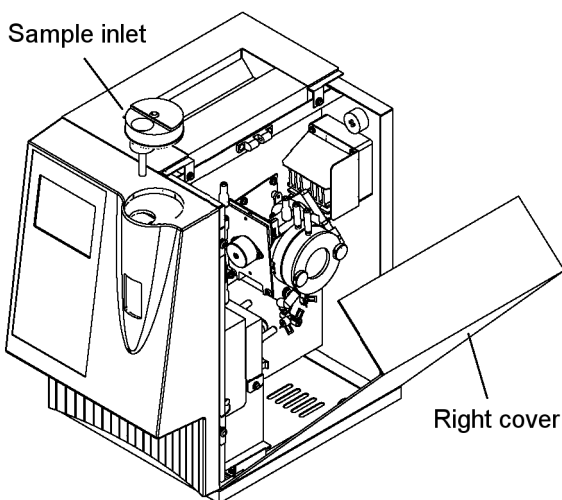

Fig. 126 Removing the sample inlet

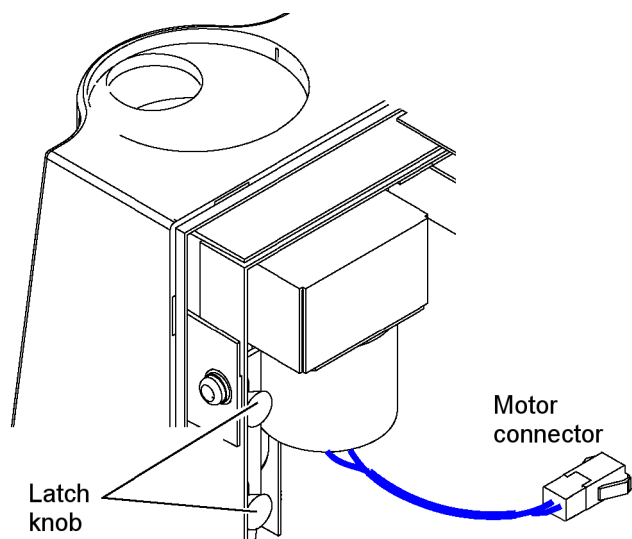

Fig. 127 Latch knobs

5. Disconnect the extractor joint and motor connector, and remove the extractor.

-
6. Use the syringe to inject air into the air hole at the top of the extractor and remove the liquid from the air hole.

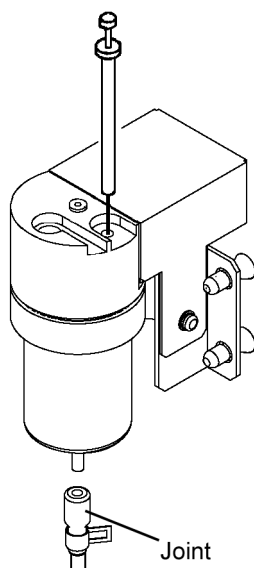





Fig. 128 Removing liquid from the air hole

7. Reverse the above procedure to replace the extractor in its original position.
8. Close the right cover and attach the sample inlet.

Replacing the water filter

 CAUTION	
	<p>Chemical hazard (solvent S-316) Inhalation or accidental ingestion of a large amount of solvent S-316 may be harmful. Observe the following rules when handling:</p> <ul style="list-style-type: none">• Ventilate the work area sufficiently.• Wear a protective mask and protective gloves.• Wash hands well after handling the solvent.
	<p>Take care not to pinch your fingers when opening or closing the right cover. During closing the right cover, do not release your hand until you hear a click sound.</p>

If sample water with a large amount of suspended material such as emulsifying substances is measured repeatedly, the water filter will clog and the following problems may occur.

- Cell filling becomes impaired and the liquid level in the extraction tank stops decreasing
- The measurement time grows longer
- Measurement accuracy becomes poorer

If any of these problems occur, the filter element of the water filter must be replaced.

■ Maintenance interval guideline

If it takes longer than 60 seconds from the start of measurement until settlement of a measured value

■ Items required

- New filter element (accessory or optional)
- Measuring cylinder (20 mL) or measuring syringe (20 mL, optional): 1 (for solvent)
- Clean solvent S-316 (optional)
- Tissue paper

■ Replacement procedure

Note

Observe the precautions below when working.

- Do not pull out the filter block with the joint attached. The joint may come off or be bent.
 - Install the water filter correctly. If poorly installed, water content in the solvent may enter the measurement cell and an abnormal measured value alarm will occur.
 - During installing the filter block after replacing the water filter, attach the joint firmly to prevent liquid leakage.
-

1. Turn OFF the power.
2. Open the right cover.

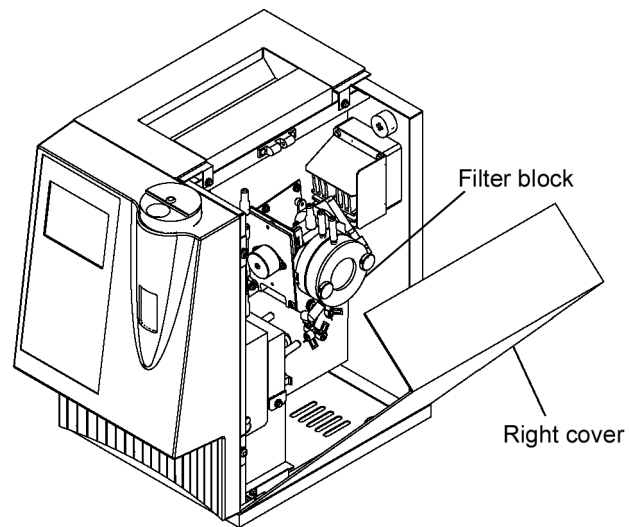

Fig. 129 Opening the right cover

3. Remove the joints from the filter block.

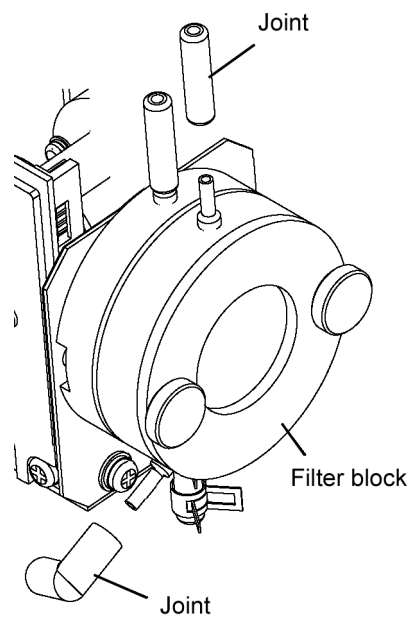

Fig. 130 Removing the joints

4. Loosen the fastening screws and remove the filter block.

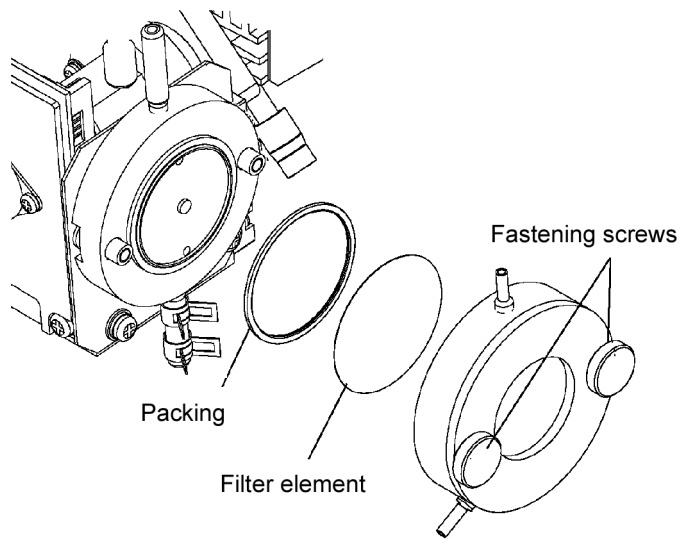

Fig. 131 Replacing the water filter element

- 5. Remove the packing and filter element, and wipe off any liquid in the filter block and on the packing with tissue paper.**
- 6. Install the new filter element and packing in the filter block.**

Note

Be sure not to let the new filter get wet. A wet filter will cause incorrect measurement results.

- 7. Tighten the fastening screws evenly to secure the filter block.**
- 8. Attach the joints to the filter block.**
- 9. Turn ON the power.**
- 10. Set the measurement mode to "MANUAL" on the Measurement Setting screen.**

Reference

- "Measurement condition settings" (page 23)
 - "Measurement Setting screen" (page 87)
- 11. Press the MEAS button or up/down button until the process display on the screen shows [Manual Measurement].**
 - 12. Use a measuring cylinder or measuring syringe (for solvent) to dispense 20 mL to 30 mL of clean solvent through the sample inlet.**
 - 13. Press the ENT button.**
The instantaneous value measurement screen appears.
 - 14. Close the drainage valve and open the fill cell valve referring to "Screen operations in the manual measurement/calibration mode" (page 14).**
Cell filling starts.
 - 15. Make sure that there is no liquid leakage from the periphery of the filter block. If liquid is leaking, remove the filter block, check the condition of the packing and filter element and then reinstall.**
 - 16. Open the fill cell valve and drainage valve referring to "Screen operations in the manual measurement/calibration mode" (page 14).**
Liquid drainage starts.

17. After liquid drainage is finished, press the ESC button.

The start state of the manual measurement mode returns.

18. Close the right cover.

Drying the measurement cell

**CAUTION****Chemical hazard (solvent S-316)**

Inhalation or accidental ingestion of a large amount of solvent S-316 may be harmful.

Observe the following rules when handling:

- Ventilate the work area sufficiently.
-
- Wear a protective mask and protective gloves.
- Wash hands well after handling the solvent.



Take care not to pinch your fingers when opening or closing the right cover.

During closing the right cover, do not release your hand until you hear a click sound.

If the measurement cell gets wet, it may cause incorrect measurement results.

■ Maintenance interval guideline

If the measurement cell gets wet

■ Items required

- Tissue paper
- Dry air
- Measuring cylinder (20 mL) or measuring syringe (20 mL, optional): 1 (for solvent)
- Clean solvent S-316 (optional)

■ Drying procedure

Note

Observe the precautions below when working.

- Do not pull out the filter block with the joint attached. The joint may come off or be bent.
 - Install the water filter correctly. If poorly installed, water content in the solvent may enter the measurement cell and an abnormal measured value alarm will occur.
 - During installing the filter block after replacing the water filter, attach the joint firmly to prevent liquid leakage.
-

1. Turn OFF the power.
2. Open the right cover.

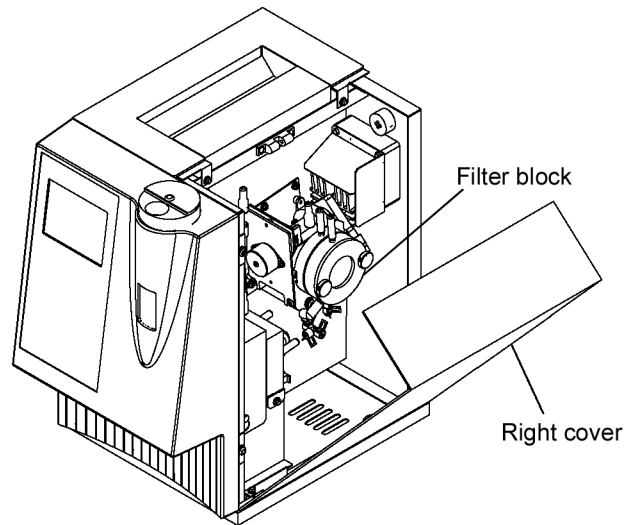

Fig. 132 Opening the right cover

3. Remove the joints from the filter block.

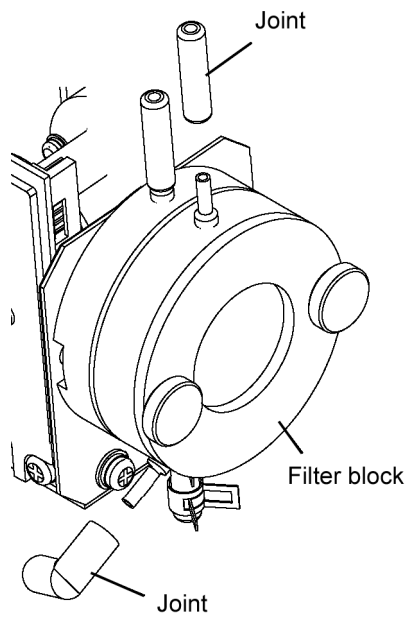

Fig. 133 Removing the joints

4. Loosen the fastening screws and remove the filter block.

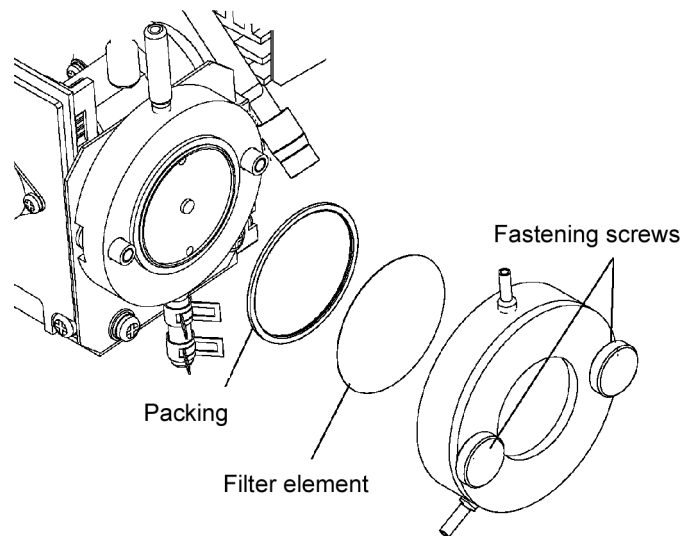

Fig. 134 Replacing the water filter element

5. Remove the packing and filter element, and wipe off any liquid in the filter block and on the packing with tissue paper.
6. Use a tissue to dab at the lower hole on the filter block, indicated by an arrow in the figure below and deliver dry air (at 0.02 MPa or less) through the air vent pipe for 5 minutes to dry the measurement cell.

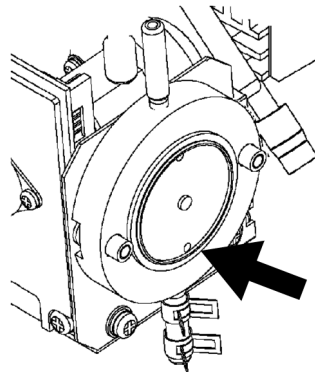

Fig. 135 Lower hole on the filter block

7. Place the filter element and packing back in the filter block.

Note

Be sure not to let the new filter get wet. A wet filter will cause incorrect measurement results.

8. Tighten the fastening screws evenly to secure the filter block.
9. Attach the joints to the filter block.
10. Turn ON the power.

11. Set the measurement mode to "MANUAL" on the Measurement Setting screen.

Reference

- "Measurement condition settings" (page 23)
 - "Measurement Setting screen" (page 87)
-
12. Press the MEAS button or up/down button until the process display on the screen shows [Manual Measurement].
 13. Use a measuring cylinder or measuring syringe (for solvent) to dispense 20 mL to 30 mL of clean solvent through the sample inlet.
 14. Press the ENT button.
The instantaneous value measurement screen appears.
 15. Close the drainage valve and open the fill cell valve referring to "Screen operations in the manual measurement/calibration mode" (page 14).
Cell filling starts.
 16. Make sure that there is no liquid leakage from the periphery of the filter block. If liquid is leaking, remove the filter block, check the condition of the packing and filter element and then reinstall.
 17. Open the fill cell valve and drainage valve referring to "Screen operations in the manual measurement/calibration mode" (page 14).
Liquid drainage starts.
 18. After liquid drainage is finished, press the ESC button.
The start state of the manual measurement mode returns.
 19. Close the right cover.

Troubleshooting

Alarm displays and actions

If an alarm occurs, the alarm icon at the top of the LCD flashes.
You can check the current alarm on the Current Alarm screen.

Reference

For information on the Current Alarm screen, refer to "Current Alarm screen" (page 71).

■ List of alarms

Display	Description	Cause	Action
System Failure	An error occurred due to insufficient RTOS resources.	An internal problem other than those below occurred.	Contact your local dealer or service station.
Clock	The clock was reset because power was not supplied to RTC during startup.	The clock battery is dead.	The date and time are initialized to 2001/01/01 00: 00:00. Refer to "System Setting screen" (page 103) to set the date and time. The alarm will be cleared until the power is turned OFF. Contact your local dealer or service station to replace the clock battery.
Load (Fact)	Failed to read factory settings.	The internal memory has failed.	Contact your local dealer or service station.
Load (User)	Failed to read general settings.	The internal memory has failed.	Contact your local dealer or service station.
Load (Meas)	Failed to read the measurement history.	The internal memory has failed.	Contact your local dealer or service station.
Load (Calib)	Failed to read the calibration history.	The internal memory has failed.	Contact your local dealer or service station.
Load (Alarm)	Failed to read Alarm History.	The internal memory has failed.	Contact your local dealer or service station.
Save (Fact)	Failed to save or delete factory settings.	The internal memory has failed.	Contact your local dealer or service station.
Save (User)	Failed to save or delete general settings.	The internal memory has failed.	Contact your local dealer or service station.
Save (Meas)	Failed to save or delete measured values.	The internal memory has failed.	Contact your local dealer or service station.
Save (Calib)	Failed to save or delete the calibration history.	The internal memory has failed.	Contact your local dealer or service station.
Save (Alarm)	Failed to save or delete Alarm History.	The internal memory has failed.	Contact your local dealer or service station.
Motor (U)	Hardware error in flow path switching motor at top of the main unit.	The motor has failed.	Contact your local dealer or service station.
Motor (L)	Hardware error in flow path switching motor at bottom of the main unit.	The motor has failed.	Contact your local dealer or service station.

Troubleshooting

Display	Description	Cause	Action
Motor (S)	Hardware error in stirrer motor.	The motor has failed.	Contact your local dealer or service station.
Flow (U)	Flow path switching at the top of the main unit does not finish within the specified time.	The motor has failed.	Contact your local dealer or service station.
Flow (L)	Flow path switching at the bottom of the main unit does not finish within the specified time.	The motor has failed.	Contact your local dealer or service station.
Heater Temp	The measurement temperature is different from the target temperature of temperature control.	The heater or the temperature sensor has failed.	Contact your local dealer or service station.
Internal Temp	The measurement temperature is not within the temperature range at which measurement results can be guaranteed.	The internal temperature is high.	Contact your local dealer or service station.
Light	Drop in output from light source or broken wire.	The light source has deteriorated or a wire is broken.	Contact your local dealer or service station.
Warm-Up	Warming up.	The power has just been turned ON.	The message will clear 30 minutes after the power is turned ON.
Stability	The range cannot be determined within the specified time, or the measured value does not stabilize within the specified time.	The right cover is open.	Close the right cover.
		Insufficient sample volume.	Prepare a total sample volume of 24 mL to 30 mL.
		Room temperature or sample temperature is high.	Keep the room temperature or sample temperature constant referring to "Problems related to measured values" (page 127).
Invalid Data	An error occurred during measurement or the value was measured during warm-up.	Measurement was performed during warm-up.	Wait at least 30 minutes after turning ON the power before performing measurement.
Calib. Failure	Zero calibration or span calibration failed.	Abnormal calibration liquid concentration.	Check the concentration of the calibration liquid and perform calibration again using the correct concentration.
		The sensor has deteriorated.	Contact your local dealer or service station.
Meas. Range	The calculated measured value is outside the measurement range.	The concentration of the sample liquid is outside the range from -20 mg/L to 220 mg/L.	Refer to "Problems related to measured values" (page 127). If needed, re-prepare the sample liquid and perform measurement again.
		The sensor has deteriorated.	Contact your local dealer or service station.

Problems not indicated by an alarm

Corrective actions for problems that are not indicated by an alarm are described below. If a problem other than one of the problems below occurs, or if a problem is not resolved after the corrective action is taken, contact your local dealer or service station.

■ Problems related to product operation

Problem	Cause	Action
Nothing appears on the LCD.	The power cable is not connected.	Connect the product to a power outlet with the power cable.
	The power switch is not switched ON.	Turn ON the power switch.
	A fuse has blown.	Contact your local dealer or service station.
A switch or the LCD does not work normally.	The product is in an unexpected state.	Turn the power OFF and ON. If the problem persists, contact your local dealer or service station.
The measured value does not appear (--- appears).	Measurement has just started.	This is normal.
	The operation was interrupted.	This is normal.
The liquid level does not go down in the extraction tank during cell filling.	The water filter is clogged.	Replace the water filter (refer to "Replacing the water filter" (page 118)).
	Liquid has collected in the joint between the extraction tank and the measurement cell.	Drain manually (refer to "Drainage mode operation" (page 12)).

■ Problems related to measured values

Problem	Cause	Action
The displayed measured value is 0 mg/L to -0.3 mg/L.	The concentration of the measurement liquid is 0 mg/L.	This value is within the repeatability range of the product and is not abnormal.
The measured value is negative.	The lot or repeatability of the solvent in the sample liquid is different from that in the calibration liquid.	Use solvent of the same lot and repeatability in the calibration liquid and sample liquid. If you must use solvents of differing lots or repeatability, use a mixture of the solvents to prepare the calibration liquid and sample liquid, re-measure, and perform measurement.
	The sample water was measured after calibration with solvent only.	Calibrate using the same extraction conditions as for measurement.
The measured value is too low.	The solvent used for calibration is different from the solvent used for measurement.	Perform zero calibration, span calibration, and measurement again using the same solvent. If you must use solvents of differing lots or repeatability, use a mixture of the solvents to prepare the calibration liquid and sample liquid, re-measure, and perform measurement (refer to "Solvent S-316" (page 132)).
	The concentration of the calibration span liquid is different from [Span Point] in the calibration settings.	Prepare calibration span liquid of the same concentration as [Span Point] in the calibration settings, and perform calibration again.
	The solvent has insufficient repeatability, and the concentration of the oil content of the solvent itself is high.	Using new solvent as zero calibration liquid, measure the reprocessed solvent using the product. Discard reclaimed solvent if its concentration is more than 10 mg/L higher than that of new solvent.

Troubleshooting

Problem	Cause	Action
The measured value is too low.	The water filter is noticeably dirty.	Replace the water filter (refer to "Replacing the water filter" (page 118)).
	The sample water was measured after calibration with solvent only.	Calibrate using the same extraction conditions as for measurement.
	A sudden change of room temperature or liquid temperature occurred.	Use a thermometer to monitor the room temperature and keep the room temperature constant during measurement. When using tap water, place in a 1 L to 2 L container a few hours prior to measurement so that the liquid temperature is approximately the same as the room temperature. Measurement of low-concentration samples is particularly susceptible to changes of room temperature and liquid temperature. The effect of liquid temperature is greater than the effect of room temperature.
"UNDER" is displayed instead of the measured value.	The detected concentration of the measurement liquid is -20 mg/L or less.	Refer to the causes and actions for "The measured value is too low." and "The measured value is negative." above.
	The measurement cell is not filled with the solvent.	Wait for a while in the semi-automatic or manual measurement mode. If "UNDER" is still displayed after a while, replace the water filter (refer to "Replacing the water filter" (page 118)).
The measured value is too high.	The solvent contains more water than usual due to the effects of emulsifying substances.	Perform extraction outside of the product, remove water from the solvent layer, and use the result as the measurement liquid (refer to "Examples of measurement by extraction outside the product" (page 61)).
	Water has entered the measurement cell.	Dry the measurement cell referring to "Drying the measurement cell" (page 121).
"OVER" is displayed instead of the measured value.	The detected concentration of the measurement liquid is 220 mg/L or more.	Refer to the causes and actions for "The measured value is too high." above.
	The measurement cell is not filled with the solvent.	Wait for a while in the semi-automatic or manual measurement mode.
The measured value is different than expected.	The amount of sample water or solvent is incorrect.	Measure using 16 mL of sample water and 8 mL of solvent.
	Incorrect calibration liquid concentration.	Perform zero calibration and span calibration again using the correct concentration of calibration liquid.
	The solvent used for calibration is different from the solvent used for measurement.	Perform zero calibration, span calibration, and measurement again using the same solvent.
	Insufficient liquid in the measurement cell.	Replace the water filter (refer to "Replacing the water filter" (page 118)).
	The ambient temperature is outside the operating temperature range.	Perform measurement in a location where the ambient temperature range is 0°C to 40°C .
	The numbers of purges are too low.	Increase the numbers of purges.
	The span liquid concentration is too low.	Use the span liquid of 10 mg/L or higher concentration.

Note

- Even when the same solvent is used for calibration and measurement, minute water content effects may cause the indicated value to be negative. If needed, remove water from the solvent layer referring to "Examples of measurement by extraction outside the product" (page 61), and then perform measurement.
 - If ultrasonic treatment or filtration under reduced pressure is performed in measurement such as that of residual oil content, the state of the solvent may change and cause the indicated value to be negative. Calibrate using solvent given the same treatment.
 - If solvents of differing lots or repeatability are used for calibration and measurement, you can measure the solvent to be used for measurement and subtract this value from the measured value of the sample liquid to learn the concentration of the oil content of the sample.
(Concentration of oil content of sample) = (Measured value of sample liquid) - (Measured value of solvent used for measurement)
-

Reference

About this product

■ Measurement principle

As indicated in Fig. 136, oils have an absorption band in the vicinity of wavelengths 3.4 μm to 3.5 μm (2941 cm^{-1} to 2857 cm^{-1}) based the expansion and contraction of groups such as (-CH₂-) and (-CH₃) that are particular to hydrocarbons.

This product calculates the concentration of oil content by measuring this infrared absorption.

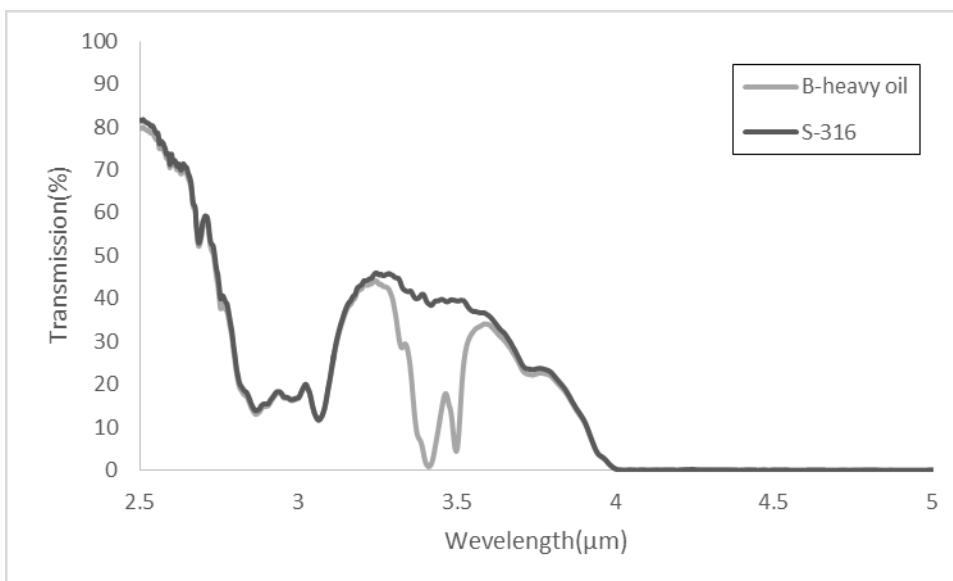

Fig. 136 Infrared absorption spectrums of solvent S-316 and oil

The solvent S-316 that is used for extraction has the following characteristics.

- Less absorption in the vicinity of wavelengths 3.4 μm to 3.5 μm (2941 cm^{-1} to 2857 cm^{-1})
- Does not blend with water
- Large difference in specific gravity with water
- Easily dissolves oil

These properties can be used to extract (dissolve) oil dispersed in water into solvent S-316 and then measure the concentration of the oil content of the sample water by means of the changes in the amount of absorption of infrared light in the vicinity of wavelengths 3.4 μm to 3.5 μm of the extracted liquid.

■ Measurement time

This product automatically determines the stability of the measured value. For this reason, at least 20 seconds is required from the start of measurement until display of the measurement results.

The flow of measurement is as follows:

1. The 10-second moving average is obtained for the measured value of 1-second sampling.
2. If the change of moving average over 10 seconds is less than 0.1 mg/L, the measured value has stabilized.
3. The moving average at this point is displayed as the measurement result.

Conversion of measurement units

If the measurement units are set to mg/kg, mg/g, or mg/PC, the value, which is converted from the value measured in mg/L, is displayed. The conversion equations are shown below.

■ mg/kg

$$\text{RESULT (mg/kg)} = \text{RESULT} \times \frac{\text{SOLVENT}}{\text{SAMPLE}}$$

RESULT (mg/kg): mg/kg converted value (mg/kg)

RESULT: mg/L measured value (mg/L)

SOLVENT: Solvent volume setting/1000 (L) (Refer to "Solvent Vol." (page 93).)

SAMPLE: Sample volume setting (kg) (Refer to "Sample Vol." (page 94).)

■ mg/g

$$\text{RESULT (mg/g)} = \text{RESULT} \times \frac{\text{SOLVENT}}{\text{SAMPLE}}$$

RESULT (mg/g): mg/g converted value (mg/g)

RESULT: mg/L measured value (mg/L)

SOLVENT: Solvent volume setting/1000 (L) (Refer to "Solvent Vol." (page 93).)

SAMPLE: Sample volume setting (g) (Refer to "Sample Vol." (page 94).)

■ mg/PC

$$\text{RESULT (mg/PC)} = \text{RESULT} \times \frac{\text{SOLVENT}}{\text{SAMPLE}}$$

RESULT (mg/PC): mg/PC converted value (mg/PC)

RESULT: mg/L measured value (mg/L)

SOLVENT: Solvent volume setting/1000 (L) (Refer to "Solvent Vol." (page 93).)

SAMPLE: Sample volume setting (PC) (Refer to "Sample Vol." (page 94).)

Solvent S-316

■ Characteristics

Solvent S-316 has the characteristics shown below, and satisfies the conditions required of a solvent for oil content extraction.

- Although there is absorption near the 3000 cm⁻¹ absorption wavelength of the hydrocarbon group, this absorption can be clearly distinguished from that of oil.
- Available for measurement in wide range of temperature due to the boiling point of 134°C and the melting point of -143°C.
- Chemically stable in acid, alkali, oil and water.
- Little solubility in water.
- Involatile, with a low vapor pressure.
- Non-flammable, no danger of explosion
- Low toxicity for the human body, very safe.

■ Properties of S-316

Chemical formula	Cl(CF ₂ -CFCl) ₂ Cl
Molecular weight	304
Boiling point	134°C
Melting point	-143°C
Density	1.75 g/mL (25°C)
Vapor pressure	0.0015 MPa (25°C)
Saturated solubility in water	0.0048 g/100 g (25°C)
Acute oral toxicity (LD50)	52.5 g/kg or more

■ Reclamation of solvent

To reduce running costs and help protect the global environment, it is recommended that S-316 is reclaimed. To reclaim solvent, use the optional SR-305 solvent reclamation unit.

— Tip —

Solvent reclamation unit (SR-305) uses activated carbon and alumina layers to efficiently reclaim the solvent.

For the solvent reclamation procedure, refer to the manual for the SR-305 solvent reclamation unit.

This section describes handling methods and cautionary points for efficient reclamation of solvent.

● Absorbents

The following 2 types of absorbents are used in the solvent reclamation unit.

- Activated carbon:
Removes oils, fats, and other substances that do not dissolve in water.
- Activated alumina:
Removes water content and substances that easily dissolve in water.

Note

Store absorbents in a dry location. If an absorbent becomes damp, its performance will drop noticeably.

● Separation of solvent

Processing time can be reduced by separating solvent with a high oil concentration from solvent a low oil concentration before reclamation.

Keep solvent, which has been used for calibration and measurement in containers separate from unused solvent, and further separate by use and/or oil concentration. For example, it is recommended that zero calibration liquid, span calibration liquid, low concentration sample liquid, and high concentration sample liquid are reclaimed separately.

● Checking the oil concentration of reclaimed solvent

After performing calibration using new solvent as calibration zero liquid, measure the oil concentration of the reclaimed solvent on the product. If the difference between the oil concentrations of the reclaimed solvent and the new solvent is 5 mg/L or less, the reclaimed solvent can be used.

■ Storing solvent

- Use a glass container to store the solvent. Do not keep it in a plastic container or metal container.

If a plastic container is used, there is a risk that plastic components from the container will dissolve into the solvent. If a metal container is used, rusting may occur due to the minute water content of the solvent and the rust will mix into the solvent.

- Mix together reclaimed solvent and store in one container.

The oil concentration of reclaimed solvent will vary with each reclamation process. Accurate measurement will not be possible if solvent conditions are changed during the course of measurement. If a large amount of solvent is necessary because you are measuring a large number of samples or otherwise, mix reclaimed solvent together in one large container to obtain the necessary amount of solvent with a uniform oil concentration.

■ Disposing of solvent

The solvent itself is a very safe chemical substance, however, dispose of solvent properly in accordance with your local and national laws.

Frequently asked questions

■ Solvents

Question	Answer
What are the main differences between analysis using S-316 and analysis using the normal hexane method (JIS K0102)?	In addition to a different extraction solvent, the principle of measurement used for the extracted oil content is different. The OCMA detects oil content by infrared absorption, whereas the normal hexane method measures the weight of the oil content. For this reason, the extraction efficiency and types of oil detected are different. In particular, the normal hexane method cannot be used to measure oil types that have a low boiling point, and thus the measured values are occasionally less well regarded.

■ Measurement

Question	Answer
Can seawater be measured?	Yes. However, zero and span calibration must be performed using seawater that does not contain oil. A salting-out effect occurs, and thus there is no problem regarding the seawater and solvent separation conditions. As long as the oil extraction ability of the solvent is the same, a seawater sample is considered to be equivalent to a fresh water sample.
Can I measure a sample water if it contains chelate compounds?	Yes. However, zero and span calibration must be performed using a chelate aqueous solution that does not contain oil. Chelates are water-soluble and thus unlikely to be extracted by the solvent. As long as the concentration is low, accurate measurement is thought to be possible.
What if the sample water contains suspended matter?	Remove the suspended matter prior to measurement. Care must be taken to not clog the joints. If the suspended matter is visible, there is a risk that the joints will become clogged. Before dispensing the sample water into the extraction tank, separate the suspended matter with a separating funnel. If suspended matter remains in the solvent layer, treat as needed by centrifugation or other method, and then carefully collect the supernatant liquid to eliminate the suspended matter. Suspended matter, which cannot be removed by the above method, must be filtered through filter paper; however, pay attention to adherence of the oil content to the filter paper.
What if the sample water contains emulsifying substances?	If the concentration of the emulsifying substances is 1 mg/L or less, measurement may be possible without further treatment. However, measurement is very difficult when the concentration is higher. Ideally the sample should be pretreated by diluting the sample water, adjusting the pH, adding table salt or Ca salt, or otherwise, to eliminate the effects of the emulsifying substances. An emulsifying substance is amphipathic, and thus not only does the emulsifying substance remain in the water tank and impede oil content extraction, but it may also be extracted into the solvent layer. The effects of the emulsifying substances on measurement results may appear in 3 ways as follows: <ul style="list-style-type: none"> ● The effect of the emulsifying substances impedes dissolution of the sample water oil content into the solvent, resulting in an indicated value that is lower than the actual oil content concentration. ● The emulsifying substance is itself dissolved into the solvent, resulting in an indicated value that is higher than the actual oil content concentration. ● The effect of the emulsifying substances increases the amount of water content dissolution, resulting in a higher indicated value.

Question	Answer
<p>What is the actual procedure for extraction analysis of the oil content of a soil sample?</p>	<p>Soil in a powder form with no water content:</p> <ol style="list-style-type: none"> 1. Remove any rocks, grass, etc. 2. Weigh out 1 g to 100 g of the soil (the optimum amount depends on the oil content concentration). 3. Add solvent to the sample and stir. 4. Filter with filter paper or quartz wool. 5. Perform measurement. <p>Soil sample containing water content:</p> <ol style="list-style-type: none"> 1. Remove any rocks, grass, etc. Add an equal or greater quantity (as the sample) of saturated saline solution to the sample and stir. 2. Add the solvent and extract the oil content. 3. Check the condition of the solvent layer. If it is difficult to separate the solvent layer, perform the next steps. If the solvent layer can be separated, go directly to step 7. 4. Discard the top saturated saline solution layer (this contains soil particles and thus is in a muddy water state) 5. Add new saturated saline solution and stir. 6. Repeat steps 4. to 5. until the emulsion layer is reduced and the solvent layer can be collected. If you run out of solvent while repeating the steps, measure more solvent, add, and stir. 7. Perform measurement. 8. Calculate the concentration from the measurement result based on the total amount of solvent.
<p>I want to measure the oil content of water, but the oil is in an emulsified state. Or, the oil is floating on the surface of the water and is also adhering to the inner sides of the container. What extraction method should I use to analyze sample water in this state?</p>	<p>Observe the following 3 points to obtain accurate measurement results.</p> <ul style="list-style-type: none"> ● Thoroughly wash the inside of the sample container with solvent until no oil adheres. ● Use a separating funnel to wash with solvent until the emulsion layer disappears. ● Sufficiently dilute sample water with floating oil before measurement. <p>An example extraction procedure is described below for reference.</p> <ol style="list-style-type: none"> 1. Pour all of the sample water in the sample container into a separating funnel. 2. Add 20 mL of saturated saline solution to the sample container and wash the inner sides, and then add this washing liquid to the separating funnel. 3. Add 10 mL of solvent to the sample container, and then add that solvent to the separating funnel. The residual oil content is dissolved. 4. Repeat steps 2. to 3. 5. Shake the separating funnel and perform extraction. 6. After letting the liquid sit, check the solvent layer. If the solvent layer cannot be collected or an emulsion layer remains, perform the next steps. If the solvent layer can be collected, collect the solvent layer and go directly to step 12. 7. Add an additional 50 mL of solvent to the separating funnel and shake well. 8. Let the liquid sit, and then collect the solvent layer while leaving the emulsion layer. 9. Repeat steps 7. to 8. until the emulsion layer disappears. 10. After the emulsion layer disappears, add an additional 50 mL of solvent to the separating funnel and shake well. 11. Let sit, and then collect the solvent layer. 12. Measure the total volume (mL) of the collected solvent with a measuring cylinder. 13. Dilute if necessary, and then measure the collected solvent on the OCMA.

■ Solvent reclamation unit SR-305

Question	Answer
When solvent is passed through new activated carbon, heat generation occurs and almost no solvent can be collected. What should I do?	When using new activated carbon, reclaim 300 mL of used solvent in advance. This solvent will almost completely disappear due to adsorption by the activated carbon surface and heat generation. Let the activated carbon tank cool to room temperature. Solvent reclamation will now be possible.
Is the heat generated by activated carbon dangerous?	As long as there is good ventilation, it is not dangerous. However, take care not to directly inhale vaporized solvent. Activated carbon generates heat up to a temperature of 70°C, however, it cools in approx. 30 minutes.
How long does reclamation take?	For example, it may take from 30 minutes to 45 minutes to reclaim 500 mL of solvent.
Is it necessary to measure the oil content concentration of reclaimed solvent?	Yes. As a guideline, make sure the concentration is 5 mg/L or less. The removal efficiency of some oil types is poor, and in some cases 5 mg/L or less cannot be attained. In this event, repeat reclamation 2 or 3 times, and make sure the concentration is constant.
A negative value is shown for the oil content concentration of reclaimed solvent. Can this solvent be used?	Yes. Perform calibration using zero liquid and span liquid prepared with that reclaimed solvent, and accurate measurement will be possible. The oil content concentration of reclaimed solvent is often 0 mg/L or less.
The flow speed of the solvent is slow. What should I do?	The water separation tank filter may be clogged. Discard water that has collected in the separation filter, and replace the water separation filter if dirty. If the flow speed does not improve after the above measures, replace the activated carbon and activated alumina. You should normally be able to collect solvent at a rate of 11 mL/min to 17 mL/min.
What is the role of activated alumina in the reclamation unit?	It removes high-polarity compounds (hydrophilic compounds). This improves the separation conditions when oil content is extracted from water.
Can activated carbon that has been used to reclaim H-997 be used to reclaim S-316?	No. Oil content and dirt adsorbed when the H-997 was reclaimed may dissolve into the S-316. Before reclaiming S-316, always replace with new activated carbon and new activated alumina.
How should the reclamation unit be stored?	Remove the activated carbon, move the solvent to a glass container with a lid (a screw-top bottle is recommended) or other airtight container to prevent solvent volatilization, and store in a cool dark location.
After using a reclamation unit, I left it without following the storage procedure. Can I still use it?	Yes. However, if left for more than 1 week, the activated carbon will dry out, and thus the first approx. 200 mL of solvent that is passed through the unit will be adsorbed by the surface of the activated charcoal (heat generation will not occur). The oil content removal ability will remain the same as previously.
If used solvent has been saved, at what point should it be reclaimed?	It is recommended that you collect as much used solvent as possible and reclaim it in one batch. Each time reclamation is performed, the amount of solvent reclaimed decreases due to adsorption by the dried activated carbon, and thus reclaiming in small batches results in a poorer reclamation rate. For example, approx. 2400 mL of reclaimed solvent can be obtained from 3300 mL (approx. 5 bottles) of used solvent (reclamation rate: approx. 73%), whereas approx. 350 mL of reclaimed solvent can be obtained from 645 mL (approx. 1 bottle) of used solvent (reclamation rate: 54%).

Question	Answer
What are the guidelines for replacement of activated carbon and activated alumina?	<p>In general, replace both the activated carbon and activated alumina when the aggregate load oil quantity exceeds 1400 mg. However, the critical load oil quantity depends on the oil type.</p> <p>The aggregate load oil quantity can be calculated from the oil content concentration and amount of reclaimed solvent using the equation below.</p> <p>Aggregate load oil quantity = Oil content concentration of reclaimed solvent × Quantity of reclaimed solvent</p> <p>For example, when 70 L of 20 mg/L used solvent is reclaimed, the aggregate load oil quantity is 1400 mg.</p>
How should used activated carbon and activated alumina be disposed of?	Dispose of activated carbon as burnable waste, and activated alumina as non-burnable waste or waste plastic.
How can I increase the amount of solvent reclaimed?	<p>It may be possible to increase the reclamation rate by reducing the amount of activated carbon. However, this will decrease reclamation ability, and should only be done when the used solvent has a low oil content concentration.</p> <p>For example, if the oil content concentration of the used solvent is 10 mg/L or less, it may be possible to increase the amount reclaimed by decreasing the amount of activated carbon by 1/3 to 1/2.</p>

Product Information

Specifications

Model	OCMA-500
Product name	Oil content analyzer
Measurement method	Solvent extraction - non-dispersive infrared absorption analysis method
Measured objects	Substances extracted from sample water into solvent and having infrared absorption near a wavelength from 3.4 μm to 3.5 μm
Measurement range	0 mg/L to 200 mg/L
Resolution	For mg/L 0 to 99.9: 0.1, 100 to 200: 1 For mg/g, mg/kg, mg/PC 0 to 9.99: 0.1, 10.0 to 99.9: 0.1, 100 to 200: 1
Repeatability	0 mg/L to 9.9 mg/L: ± 0.3 mg/L. 10.0 mg/L to 99.9 mg/L: ± 2.1 mg/L. 100 mg/L to 200 mg/L: ± 5 mg/L. * For standard liquids
Display method	3.5 inches, 320 \times 240 dots, Backlight Color graphic LCD
Calibration method	Zero, span calibration
Amount of test sample required	Sample water : Solvent = 2:1
Extraction solvent	S-316
Amount of extraction solvent required	8 mL
Extraction method	Built-in extractor
Ambient operating temperature	0°C to 40°C (no condensation)
Power supply	AC 100 V to 240 V $\pm 10\%$, 50/60 Hz
Power consumption	AC 100 V: Approx. 60 VA, AC 240 V: Approx. 90 VA
External dimensions	342 (H) \times 200 (W) \times 313 (D) mm
Mass	Approx. 7 kg
External output	Output to a USB memory stick
Functions	<ul style="list-style-type: none"> ● 300-item data memory ● Self error determination ● Stabilized measurement value display ● Clock ● Compliant with ASTM D7066-4

List of optional parts

Name	Part No.	Specifications
Dropper	3011025237	Polyethylene, 2.5 mL
Microsyringe	3200043748	25 μL
Measuring syringe	3014054647	For solvent, 20 mL
Measuring syringe	3014054648	For sample, 20 mL
Absorbent sheet	3200549145	3 in package
Filter element	3200043516	For water filter, diameter 40 mm, 5 in package
Packing	3200044264	For water filter
Packing	3200564367	For extractor
B-heavy oil	3200043747	10 mL
Solvent S-316	3200044490	1.5 kg

HORIBA Advanced Techno
<http://www.horiba-adt.jp>

Headquarters
31, Miyanonishi-cho, Kisshoin Minami-ku, Kyoto 601-8306, Japan
TEL:+81-75-321-7184 FAX:+81-75-321-7291
